

THE RACECOURSE MANUAL

Any queries with regard to the Racecourse Manual should be addressed to:

The Racecourse Department
The British Horseracing Authority
75 High Holborn
London WC1V 6LS

Tel: 020 7152 0000

© THE BRITISH HORSERACING AUTHORITY

Originally published by The Jockey Club 1992
Revised 2000, 2005, 2008 & 2010.

All rights reserved. No part of this material may be reproduced or transmitted in any form or by any means, including photocopying, recording or re-publication without the written permission of the British Horseracing Authority to whom such application for permission should be addressed. Such written permission must also be obtained if any part hereof is stored on a retrieval system of any nature.

CONTENTS

Section 1: THE COURSE

- 1.1 Introduction
- 1.2 All Weather Courses
- 1.3 Turf Courses
- 1.4 Safety Factors
- 1.5 Banking of Bends
- 1.6 Distances from Starts to Bends
- 1.7 Distances from Finish to Bends
- 1.8 Racing Surfaces
- 1.9 Crossings
- 1.10 Watering Systems
- 1.11 Drainage
- 1.12 Running Rail
- 1.13 Emergency Service Roads
- 1.14 Canter Downs
- 1.15 Floodlighting
- 1.16 Obstacles

Section 2: STARTS

- 2.1 Start Markers
- 2.2 Starters' Rostrum
- 2.3 Starting Stalls
- 2.4 Starting Gates
- 2.5 Race Timing

Section 3: OFFICIAL STABLES COMPLEX

- 3.1 Introduction
- 3.2 Location
- 3.3 Layout
- 3.4 Horse Box Park
- 3.5 Perimeter Barrier
- 3.6 Security Accommodation
- 3.7 Specification for Loose Boxes
- 3.8 Barn Stabling
- 3.9 Ancillary Requirements
- 3.10 Canteen and Overnight Accommodation Facilities

Section 4: THE PADDOCK

- 4.1 Saddling Boxes
- 4.2 Pre-Parade Ring
- 4.3 Parade Ring
- 4.4 Horsewalks
- 4.5 Unsaddling Enclosure

Section 5: WEIGHING ROOM COMPLEX

- 5.1 Layout
- 5.2 Weighing Room Work Area
- 5.3 Scales
- 5.4 Declarations Room/Counter/Desk
- 5.5 Broadcast Office
- 5.6 Handicapper's Room
- 5.7 Clerk of the Course's Room
- 5.8 Stewards' Room
- 5.9 Jockeys' Changing Rooms
- 5.10 Valets' Room
- 5.11 Jockeys' Rest Room
- 5.12 Public Address Installation
- 5.13 Jockeys' Medical Room
- 5.14 Press Interview Room
- 5.15 General Media Facilities

Section 6: JOCKEYS' MEDICAL ROOM

- 6.1 Location
- 6.2 Dimensions
- 6.3 Layout
- 6.4 Fittings

Section 7: VETERINARY FACILITIES

- 7.1 Sampling Unit
- 7.2 Veterinary Treatment Box
- 7.3 Other Requirements

Section 8: JUDGE'S BOX, PHOTOFINISH INSTALLATION, FINISHING LINE AND COMMENTARY BOX

- 8.1 Judging and Photofinish Installation
- 8.2 Judge's Box
- 8.3 Photofinish Installation
- 8.4 Finishing Line
- 8.5 Commentary Box

Section 9: TELEVISION FACILITIES

- 9.1 Television Camera Patrol Service
- 9.2 Cabling
- 9.3 Mobile Control Room (MCR) Position
- 9.4 Head-on Camera Position
- 9.5 Side-on Camera Position
- 9.6 Hoist Camera Positions

Section 10: STEWARDS' VIEWING BOXES

- 10.1 Location
- 10.2 Main Viewing Box
- 10.3 Secondary Viewing Box

LIST OF ILLUSTRATIONS & PHOTOS

- Fig. 1.A Racecourse Layout
Fig. 1.B Lay-by
Photo 1.A Boom Irrigation – Market Rasen
Photo 1.B Floodlighting – Great Leighs
Photo 1.C Plain Fence – Fontwell Park
Photo 1.D Open Ditch – Chepstow
Photo 1.E Hurdle – Bangor-On-Dee
- Fig. 2.A Starter's Rostrum
- Fig. 3.A Official Stables Complex 'Plan A'
Fig. 3.B Official Stables Complex 'Plan B'
Fig. 3.C Loading/Unloading Ramp
Photo 3.A Official Stables Complex – Warwick
Photo 3.B Loose Box – Southwell
- Fig. 4.A Suggested Diagrammatic Layout of the Paddock
Photo 4.A Saddling Boxes – Musselburgh
- Fig. 5.A Possible Layout of a Weighing Room Complex
Photo 5.A Scales Area in Weighing Room – Ascot
Photo 5.B Jockeys' Changing Room – Ascot
Photo 5.C Valets' Room – Ascot
Photo 5.D Jockeys' Rest Room – Ascot
Photo 5.E Press Room – Ascot
- Fig. 6.A Possible Layout of the Jockeys' Medical Room
Photo 6.A Jockeys' Medical Room – Great Leighs
Photo 6.B Jockeys' Medical Room Administration Area – Great Leighs
- Fig. 7.A Corridor Style Sampling Unit (4 Loose Boxes)
Fig. 7.B Work Stations in the Sampling Unit
Photo 7.A Sampling Unit – Ascot
- Fig. 8.A Photofinish Position
Fig. 8.B Judge's Box Plan
Fig. 8.C Commentary Box Location
Fig. 8.D Commentary Box Plan
Fig. 8.E Commentary Box – Elevation
- Fig. 10.A Secondary (Stewards') Viewing Box
Photo 10.A Stewards' Viewing Box – Ascot

INTRODUCTION

The purpose of the Racecourse Manual is to provide Racecourse Managing Executives, Racecourse Managers, Clerks of the Course and Architects with the basis of a blueprint of the 'ideal' specification for those facilities necessary for the conduct, integrity and safety of a raceday. On occasion, this specification exceeds the minimum standards set out in the British Horseracing Authority General Instructions (BHAGIs) and should be used by those designing a new racecourse, or by existing racecourses wanting to carry out modifications or developments to improve their present facilities.

Where reference is made to a particular BHAGI in a certain section of the Manual, it will be necessary to consult the Instruction to gain a complete understanding of the specification required. All racecourses are sent the latest BHAGIs on a regular basis. For any information on the suppliers of particular products that can be used on racecourses, it will be necessary to consult the Racecourse Suppliers Index published by the Racecourse Association Ltd., Winkfield Road, Ascot, Berks., SL5 7HX (Tel: 01344 873536). In the interests of safety, no new design, equipment or materials are to be introduced onto any racecourse for use during races without written confirmation first having been obtained from the British Horseracing Authority Racecourse Department (BHAGI 3.3).

The dimensions given in this document are normally the minimum requirement for a 'new build' racecourse. Should racecourses wish to exceed these dimensions, this will normally be acceptable, but the Racecourse Department should be consulted. Racecourses must consult the Racecourse Department at an early stage in the planning of any facilities affecting British Horseracing Authority Officials or technical services, so that potential design problems can be discussed and dealt with, and feedback be obtained from the relevant British Horseracing Authority Officials. As a statement of the ideal it is recognised that the specifications laid down in the Manual are flexible in certain situations, and that alternative solutions can sometimes be found to achieve the desired effect.

The Racecourse Manual was first published in 1992 as a reference document which held all information relating to racecourse facilities in one place. Inevitably, changes are made to the Manual as new technology is introduced and improved working practices evolve.

Racecourse Managing Executives are reminded that they are responsible for all aspects of safety at their respective racecourses. The Racecourse Manual does not absolve them of that responsibility.

Section 1

THE COURSE

Section 1: THE COURSE

- 1.1 INTRODUCTION
- 1.2 SYNTHETIC OR ALL WEATHER COURSES
- 1.3 TURF COURSES
- 1.4 SAFETY FACTORS
- 1.5 BANKING OF BENDS
- 1.6 DISTANCES FROM STARTS TO BENDS
- 1.7 DISTANCES FROM FINISH TO BENDS
- 1.8 RACING SURFACES
 - Turf*
 - Synthetic or All Weather Track (AWT)*
- 1.9 CROSSINGS
- 1.10 WATERING SYSTEMS
 - Water Quantities*
- 1.11 DRAINAGE
 - Site Investigation*
- 1.12 RUNNING RAIL
- 1.13 EMERGENCY SERVICE ROADS
- 1.14 CANTER DOWNS
- 1.15 FLOODLIGHTING
 - Light Level/Camera Picture Quality*
 - Columns*
 - Emergency Backup Power Supply*
- 1.16 OBSTACLES
 - Fences*
 - Hurdles*
 - Wings*
 - Lay-bys*

Section 1: THE COURSE

1.1 INTRODUCTION

The key dimensions and starts for any new racecourse or racetrack are set out below. The shape of the proposed site may affect the track layout which must incorporate the minimum essential dimensions. On Turf tracks, experience has shown that the minimum width should be treated as just that, in that the greater the width of track available, the greater the flexibility that will be available to provide fresh ground and, consequently, the safest going conditions. The damage inflicted by horses upon the turf during a race fixture should not be underestimated. The race distances (which are specified below for each category of racecourse) should be seen as the ideal, and some flexibility may be available, subject to agreement with the BHA Racing Department.

Within each section, all points have been categorized as either MANDATORY or HIGHLY DESIRABLE.

1.2 SYNTHETIC OR ALL WEATHER (AWT) COURSES

1.2.1 All Weather Flat Racing – Course Layout

An AWT Course:

MANDATORY:

- must, for safety and horse welfare reasons, have a minimum bend radius of 147.6 yards (135m).

Note: On rare occasion, some flexibility on bend radius may be possible (with the exception of the bend into the home straight), depending upon the super elevation (camber) required for the radius concerned. This is only possible at existing Turf Flat racecourses where:

- it is not physically possible to configure an AWT layout in conjunction with the turf facilities, so that the AWT has a minimum bend Radius of 135m;

AND

- there is no reasonable scope to acquire sufficient extra land and the AWT provision would enhance existing turf course facilities.

Furthermore, where this is the case, reduced Safety Factors, super elevation (camber) and enhanced maintenance would, from a safety perspective, probably all be necessary.

HIGHLY DESIRABLE:

- should have a course width of at least 21.9 yards (20m) catering for the maximum number of runners permitted i.e. 'the Safety Factor'. The Safety Factor will usually be 16-18, although this may vary, depending upon the start position involved (see Section 1.4 - Safety Factors). Some flexibility on course width may be possible depending on the Safety Factor intended. Furthermore, in certain circumstances on AWT tracks, a 20% reduction in the width of the course may be permitted on the bends;
- should ideally have a minimum circuit length of 1 mile 2 furlongs (2012m);
- should ideally have a straight allowing 5 furlongs (1006m) and 6 furlongs (1207m) races.

1.2.2 AWT Flat Racing – Course Distances

MANDATORY:

The means by which all courses are measured, and start positions marked, must be agreed with the BHA Inspectorate. Distances should be measured 2 yards (1.8m) from the permanent inside running rail.

HIGHLY DESIRABLE:

Depending on individual race distances, there should be a minimum of 1 furlong between any start position the starting point of any bend(s).

The key distances for Flat races, and those which racecourses should look to include are:

- *5 furlongs (preferably straight, 1006m);
- 6 furlongs (preferably straight, 1207m);
- 7 furlongs (1408m);
- 1 mile (1609 m);
- 1 mile 2 furlongs (2012m);
- 1 mile 4 furlongs (2414m);
- 1 mile 6 furlongs (2816m);
- 2 miles (3218m).

*minimum distance allowed under Rule 91(i)(b)

1.3 TURF COURSES

1.3.1 Turf Flat Racing – Course Layout

HIGHLY DESIRABLE:

A Turf Flat Course:

- should, for safety and horse welfare reasons, have a minimum bend radius of 147.6 yards (135m). Unlike AWT tracks, the migration towards the inner rail of the sand-based artificial surface (through gravity, hoof impact and maintenance practices) is not a problem on turf tracks. Nevertheless, super elevation will be required (see Section 1.5). However, it should be noted that excessive banking is detrimental to both safety and horse welfare, and will result in a topographically uneven track surface at the intersections between the bend and any start from a 'chute' which is linked to a bend;
- should have a course width of at least 25 yards (22.9m). Some flexibility on course width may be possible depending on the Safety Factor intended (see Section 1.4 – Safety Factors) and the number/timing of anticipated fixtures allocated to the course. To facilitate dolling out/in (i.e. movement of running rail to provide fresh ground) for safety and horse welfare reasons, no reduction to the specified width of the course is permitted on the bends;
- should ideally have a minimum circuit length of 1 mile 2 furlongs (2012m);
- should ideally have a straight allowing 5 furlongs (1006m) and 6 furlongs (1207m) races. The running of 6 furlongs races on a round course (instead of a straight) will be dependent on the radius of the bend and the distance from the start position to the bend.

1.3.2 Turf Flat Racing – Course Distances

MANDATORY:

See Section 1.2.2 above for the means by which courses and start positions are measured and distance from start positions to bends.

HIGHLY DESIRABLE:

The key distances for Flat races, and those which racecourses should look to include are:

- *5 furlongs (straight, 1006m);
- 6 furlongs (straight†, 1207m);
- 7 furlongs (1408m);
- 1 mile (1609m);
- 1 mile 2 furlongs (2012m);
- 1 mile 4 furlongs (2414m);
- 1 mile 6 furlongs (2816m);
- 2 miles (3218m).

*minimum distance allowed under Rule 91(i)(b)

†6 furlongs 'round' may be acceptable depending on radius of bend and start position.

1.3.3 Turf Hurdle Racing – Course Layout

HIGHLY DESIRABLE:

A Turf Hurdle course:

- should, for safety and horse welfare reasons, have a minimum bend radius of 147.6 yards (135m);
- should have a course width of at least 30 yards (27.5m). This width reflects the increased flexibility required to meet turf management demands for a sport that is, in large part, run on softer, more easily poached ground during the winter months. Furthermore, the difference in width between turf Jump and Flat tracks is due to the former requiring lay-bys (where applicable) and at least an extra 5m in width in order to allow for a hurdle/fence to be bypassed in the event of a prone horse/rider. Some track width flexibility may be possible depending on the Safety Factor intended (see Section 1.4 – Safety Factors) and the number/timing of anticipated fixtures allocated to the course. To facilitate dolling out/in (i.e. movement of running rail to provide fresh ground) for safety and horse welfare reasons, no reduction in the specified width of the course on the bends is permitted;
- should ideally have a minimum circuit length of 1 mile 2 furlongs (2012m).

1.3.4 Turf Hurdle Racing – Course Distances

MANDATORY:

See Section 1.2.2 above for the means by which courses and start positions are measured.

There must be at least 8 flights of hurdles jumped in races of 2 miles, with an additional flight jumped in each succeeding quarter mile (BHA Instruction 3.6 paragraph 1). This is the fundamental definition of a Hurdle race.

HIGHLY DESIRABLE:

The key distances for Hurdle races, and those which racecourses should look to include are:

- *2 miles (3218m);
- 2 miles 2 furlongs (3621m);
- 2 miles 4 furlongs (4023m);
- 2 miles 6 furlongs (4425m);
- 3 miles (4828m).

*minimum distance allowed under Rule 92(i)(b)

1.3.5 Turf Steeplechase Racing – Course Layout

For safety and horse welfare reasons, normal practice is for the Steeplechase course to be on the inside of the Hurdle course. This is due to the nature of

the horses, the likely longer distances (and therefore lower speed of horses running) and to the fact that Steeplechases ordinarily attract fewer runners than Hurdle races.

Assuming the Hurdle course specification adopted is as per 1.3.3 and 1.3.4 above, it follows that the Steeplechase course:

MANDATORY:

- would, for safety and horse welfare reasons, have a minimum bend radius of 125.8 yards (115m).

HIGHLY DESIRABLE:

- should have a minimum course width of 21.9 yards (20m). Some flexibility may be possible depending on the Safety Factor intended (see Section 1.4 – Safety Factors) and the number/timing of anticipated fixtures allocated to the course. To facilitate dolling out/in (i.e. movement of running rail to provide fresh ground) for safety and horse welfare reasons, no reduction of the width of the course on the bends is permitted;
- should ideally have a circuit length of 1 mile 1 furlong and 82 yards (1885.5m).

1.3.6 Turf Steeplechase Racing – Course Distances

MANDATORY:

See Section 1.2.2 above for the means by which courses and start positions are measured.

There must be at least 12 fences in races of 2 miles, with at least 6 fences in each succeeding mile. There is to be one open ditch for each mile. A water jump may be included (BHAGI 3.5 paragraph 1). This is the fundamental definition of a Steeplechase.

HIGHLY DESIRABLE:

The key distances for Steeplechase races, and those which racecourses should look to include are:

- *2 miles (3218m);
- 2 miles 2 furlongs (3621m);
- 2 miles 4 furlongs (4023m);
- 3 miles (4828m);
- 3 miles 2 furlongs (5230m).

*minimum distance allowed under Rule 92(i)(b)

1.3.7 Dimensions Summary

Developers may propose an overall course layout which combines any permutation of the above racing codes. However, the layout should comply with the minimum dimensions specified above.

In the case of a Turf racecourse catering for Flat racing, Steeplechasing and Hurdling, when the latter two courses are built to meet specifications laid out in 1.3.3 and 1.3.5, it follows that the Flat course would be sited as the outermost course for safety and horse welfare issues. This is because Flat races are run at greater speeds than Jump races. Consequently, the Flat track:

- would have bend radii of 169.5 yards (155m);
- would ordinarily consist of a circuit of 1 mile 2 furlongs and 136 yards (2136m).

The overall width of racing surface required to cater for all three courses will be 76.9 yards (70.4m).

1.4 SAFETY FACTORS (for information)

The Safety Factor is the maximum number of runners allowed by the BHA Inspectorate, for safety and horse welfare reasons, to start at each race distance on a given course.

The Figure is dependent upon race code (i.e. Flat, Hurdle or Steeplechase) and is set and constantly monitored by the BHA Inspectors of Courses, in discussion with and the agreement of Clerks of the Course and Safety Officers of the Professional Jockeys Association (PJA). In addition, the PJA and National Trainers Federation formally endorse existing Safety Factors at all courses on an annual basis.

There is flexibility to reduce Safety Factors temporarily at any racecourse where track modifications (e.g. running rail movements) are made, as necessary, to provide optimum turf conditions.

1.5 BANKING OF BENDS

MANDATORY:

The super elevation (camber) required for any bend radii will be dependent on a number of factors surrounding the existing topography of the site involved. An agreed industry developed model is in place, relating bend radii to the degree of banking needed to optimise safety and welfare for horse and rider when travelling around a bend at various speeds. As such, the BHA Racecourse Department must be consulted before any final design can be agreed for a bend's construction/modification.

1.6 DISTANCES FROM STARTS TO BENDS

HIGHLY DESIRABLE:

The minimum distance from a start to a bend should be at least 1 furlong (201m) for flat courses. However, there may be some flexibility with this distance for hurdle and steeplechase courses, dependent on Safety Factors and bend radii (a lower Safety Factor, position of first obstacle and/or greater bend radius can result in a lesser distance between start and bend being acceptable).

1.7 DISTANCES FROM FINISH TO BENDS

MANDATORY:

For safety and horse welfare purposes, the finish must be on the straight and not on a bend. Providing the bend radii are of 135m or more, there is no need to provide a further length of straight after the winning post.

1.8 RACING SURFACES

Turf

HIGHLY DESIRABLE:

There is no specified ideal turf racing surface, since the growth of turf is dependent on geographical position, soil type, maintenance regimes, drainage properties, irrigation capabilities etc. The best turf is that which has a hard-wearing, healthy sward, a good and strong root structure, drains well and is not prone to excessive compaction. Advice on purpose built turf track profiles, as well as appropriate grass cultivars, should be obtained from a turf consultant.

Synthetic or All Weather Track (AWT)

MANDATORY:

Any surface being used on a Synthetic or All Weather Track must, for safety and horse welfare reasons, receive BHA approval. The approval protocol is industry agreed, coordinated by the BHA Racecourse Department, and carried out in conjunction with Jockeys and Trainers with additional advice from BHA medical/veterinary sources. There is currently a variety of AWT surfaces that carry such approval. The surfaces must be laid down and maintained in line with the suppliers' instructions, and Racecourse Executives must also enlist the services of a consultant in order to provide an annual report to BHA on the condition of the track against certain key performance criteria.

1.9 CROSSINGS

MANDATORY:

Although some racecourses presently have permanent vehicular course crossings, these will not be permitted as part of a new development.

1.10 WATERING SYSTEMS

MANDATORY:

Racecourses must have a course watering system (including pump and back-up) and a water supply (e.g. a reservoir/bore hole/river) available, compatible with the code and programme of racing, as well as with the dimensions of the racing surface. This is imperative for good turf management and participant safety/welfare. Any watering system must be capable of achieving both the going aims and watering capabilities highlighted in BHAGI 3.2. Specialist advice should be taken with regard to watering systems but, in general terms, it is advisable to use a boom type method of application (see Photo 1.A) which applies irrigation consistently and downwards, thereby minimising the impact of wind disruption.

To determine the water requirements (and therefore the volume of water required), it is essential to relate the volume of water needed to the area of turf to be watered. For example, a mile of track with an average watered width of 27m gives an area to be watered of approximately 4.5 hectares.

Watering Quantities (For Information)

2.5cm of water over 1 hectare of ground = 254,500 litres. Allowing for 10% evapotranspiration losses this will, in 'real terms' equate to 279,900 litres. Four weeks of drought would therefore equate to 5.04 million litres of water. Obviously, it is likely that this requirement will be at least partially met by natural rainfall. However, new Course Executives must be fully aware of the need to have an appropriate water supply, in order to ensure that racing is not compromised when very firm conditions prevail. See BHAGI 3.2 for further information.

1.11 DRAINAGE

HIGHLY DESIRABLE:

A drainage system helps to minimise the risk of waterlogging, as well as to ensure that suitable racing conditions are provided as per BHAGI 3.2 paragraph 2.

Site Investigation

For safety reasons, it is essential that a full site investigation be undertaken to determine the problems, site levels, suitability of outlets and other relevant factors, in order to ensure that the correct design is selected. It is strongly recommended that advice be taken from a turf consultant. As required by BHAGI 3.2, clearance from the BHA's Racecourse Department is also required before carrying out any course related drainage work.

1.12 RUNNING RAIL

MANDATORY:

Running rails must be of a variety currently approved by the BHA (in line with industry agreed testing protocol overseen by BHA's Racecourse Department), date stamped with year of manufacture, and be erected to define the entire racing surface. In addition, for safety reasons, any solid fencing or crowd barrier must be erected a minimum of 2m from running rail that defines the racing surface.

Points of access to the course must have running rails which are colour distinguished in order to minimise incident response times for service vehicles (medical, veterinary, groundstaff personnel etc.).

1.13 EMERGENCY SERVICE ROADS

MANDATORY:

A service road must be provided, giving access to all parts of the racing surface. For safety reasons, the service road must be suitable for all types of vehicle and be made of tarmac. This ensures that all essential services (such as doctors, ambulances, vets, horse ambulances and recovery vehicles) can get to all parts of the course. Passing places must be included for emergencies. Provision must also be made for moving starting stalls efficiently on to and off the course at each Flat start. Appropriate safety measures must be taken by the Course Executive wherever spectators are likely to gather in the immediate vicinity of the service road.

1.14 CANTER DOWNS

MANDATORY:

For turf management reasons, it is mandatory for any new Jump courses to provide a dedicated canter down. It is recommended that canter downs be at least 3m wide and be railed on both sides by an approved running rail. For safety reasons, any crowd barrier or fencing must be a minimum of 2m behind the running rail (see BHAGI 3.4 for further information). Canter downs can consist of turf or of any synthetic surface approved by the BHA.

1.15 FLOODLIGHTING

MANDATORY (IF APPLICABLE):

All racecourse floodlighting systems must be installed, operated and maintained in line with the manufacturer's operating instructions. They must be wired in accordance with the Institution of Electrical Engineers Wiring Regulations, by an organisation approved by the National Inspection Council for Electrical Installation Contracting (NICEIC).

Light Level/Camera Picture Quality

For safety and horse welfare reasons, the vertical lighting illuminance of the floodlights must reach a minimum of 700 Lux. However, where the distance between the Photofinish mirror and the Judge's Box is more than 85m, the light level around the track (particularly in the home straight) will need to be much higher. Furthermore, the recommended level of vertical illuminance also depends on the sensitivity of the cameras being used to relay television pictures. To ensure that acceptable colour camera patrol pictures are obtained, racecourses should liaise closely with the BHA's Racecourse Department, as well as with the contracted integrity service provider.

Columns

For integrity reasons, the location of columns used to mount lamps must take account of sight lines from all Stewards' Boxes. The positioning of the columns must also be such that it produces an illuminated side-on view from the grandstand, as silhouetting of the horses is unacceptable. For safety and horse welfare reasons, columns must be situated at least 2m from the running rail (see Photo 1.B) and, if less than 4m from the running rail, must also be padded. Furthermore, columns must be located in such a way that they do not create a pronounced shadowing effect on any of the courses being used, to the extent that horses would be liable to jump any shadow(s) cast.

Emergency Backup Power Supply

For integrity, as well as for safety reasons, there must be a suitable, separate and continuously running emergency power supply available for immediate use in the event of an electrical failure. This secondary source of power supply must continuously supply at least 10% of the track illumination level, and supply power to Officials' rooms and broadcast facilities. Where the secondary power source is not provided by a generator, but via the Electricity Board's mains, it must be from a different part of the Board's supply network to that of the primary source.

1.16 OBSTACLES

MANDATORY:

Fences

See BHAGI 3.5 for current specifications. See also Photos 1.C and 1.D.

Hurdles

See BHAGI 3.6 for current specifications. See also Photo 1.E.

Wings

These must be provided at all obstacles to the dimensions specified in BHAGIs 3.5 & 3.6.

Lay-bys

For safety and horse welfare reasons, lay-bys must be installed on the inside of obstacles, where applicable. Each Lay-by must be approximately 4m in width immediately adjacent to the obstacle, this width diagonally reducing to 0m at 30m beyond the obstacle, where it meets the inside racing line. See Sections 1.3.4 and 1.3.6 for numbers of obstacles required.

Fig. 1.A

Fig. 1.B

Photo 1.A Boom Irrigation – Market Rasen

Photo 1.B Floodlights – Great Leighs

Photo 1.C Plain Fence – Fontwell Park

Photo 1.D Open Ditch – Chepstow

Photo 1.E Hurdle – Bangor-On-Dee

LAY-BY
FIG. 1.B

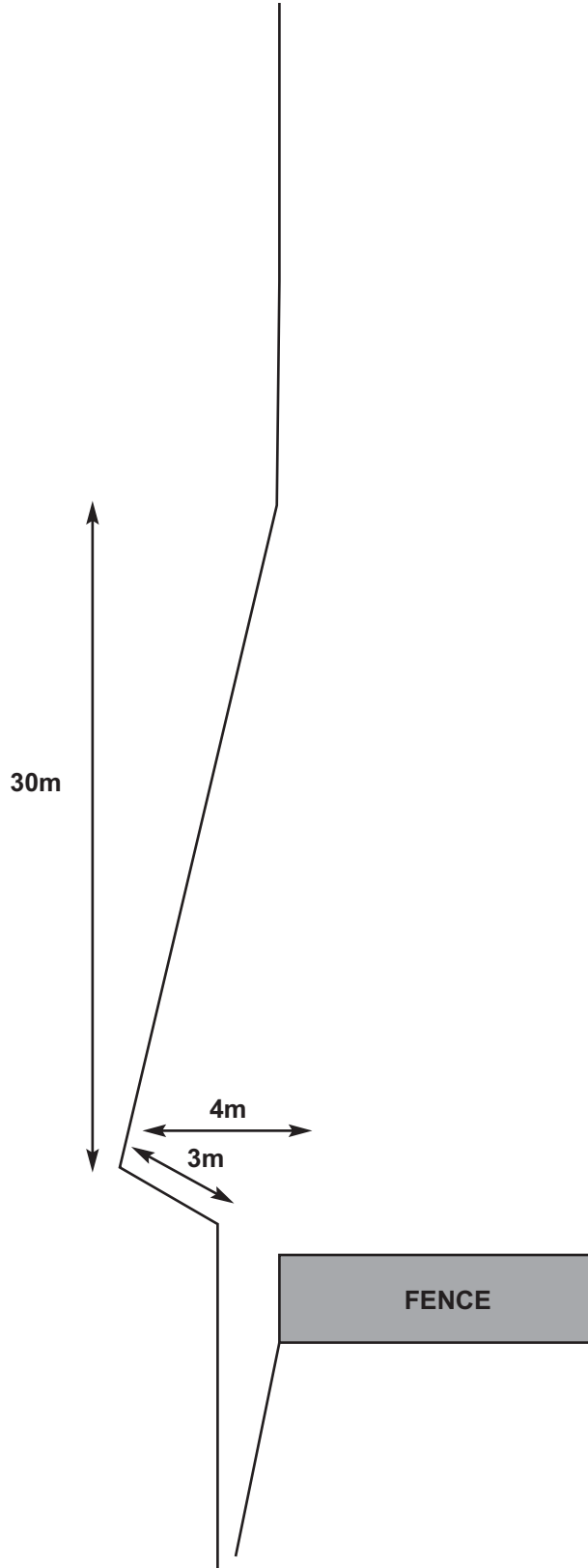



Photo 1.A Boom Irrigation – Market Rasen



Photo 1.B Floodlighting – Great Leighs



Photo 1.C Plain Fence – Fontwell Park



Photo 1.D Open Ditch – Chepstow



Photo 1.E Flight of Hurdles – Bangor-On-Dee

Section 2

STARTS

Section 2: STARTS

- 2.1 START MARKERS
- 2.2 STARTER'S ROSTRUM
- 2.3 STARTING STALLS
- 2.4 STARTING GATES
- 2.5 RACE TIMING

Section 2: STARTS

2.1 START MARKERS

All starting positions are to be marked by a permanent sign with letters/numbers which clearly show the distance of races started from them. For Flat racing, a specific marker must also be set flush into the ground. This must consist of a painted concrete block 200mm x 400mm positioned at least 1m behind the running rail.

2.2 STARTER'S ROSTRUM

On both Flat and Jump courses, a Starter's rostrum must be provided.

The Starter's rostrum must not be less than 1.35m high. It must have flat, gently ascending steps with handrail, be of a non-slip surface, and be positioned before the start of each race so that the steps are facing the horses. The rostrum platform must measure no less than 0.8m x 0.8m (see Fig. 2.A).

2.3 STARTING STALLS

The starting stalls for a raceday should be provided by the Course Executive or an outside integrity service provider, along with trained, BHA accredited handling staff. In order that the starting equipment can function properly the racecourse must provide the following:

- a hard standing area for unloading and parking. Dimensions are dependant upon the stalls design and the number of sets utilised, but the hard standing area may need to be at least 32m in length and 10m wide. It should be located adjacent to the course, along the straight;
- easy access to the course itself at start positions (see Section 1.13). Firm level tracks and slip rails on both sides providing a minimum gap of 4m are required, as is space for accommodating those stalls not in use;
- a hard route from start to start with a turning circle onto the course.

Where applicable, provision for secure, non-raceday parking for starting stalls should be agreed between the Course Executive and any starting stalls provider.

See BHAGI 4.3 for details of ancillary equipment, personnel and equipment maintenance.

2.4 STARTING GATES

There are two types of starting gates available for use on Jump courses: the 'Flip' start and the Gill and Punter 'Barrier Gate'.

See BHAGI 10.1.

All timing is carried out using radio transmitting equipment to trigger the clock. If race timing is required by the racecourse it can be provided by the integrity service provider, who should be consulted at an early stage.

Fig. 2.A

STARTER'S ROSTRUM
FIG 2.A

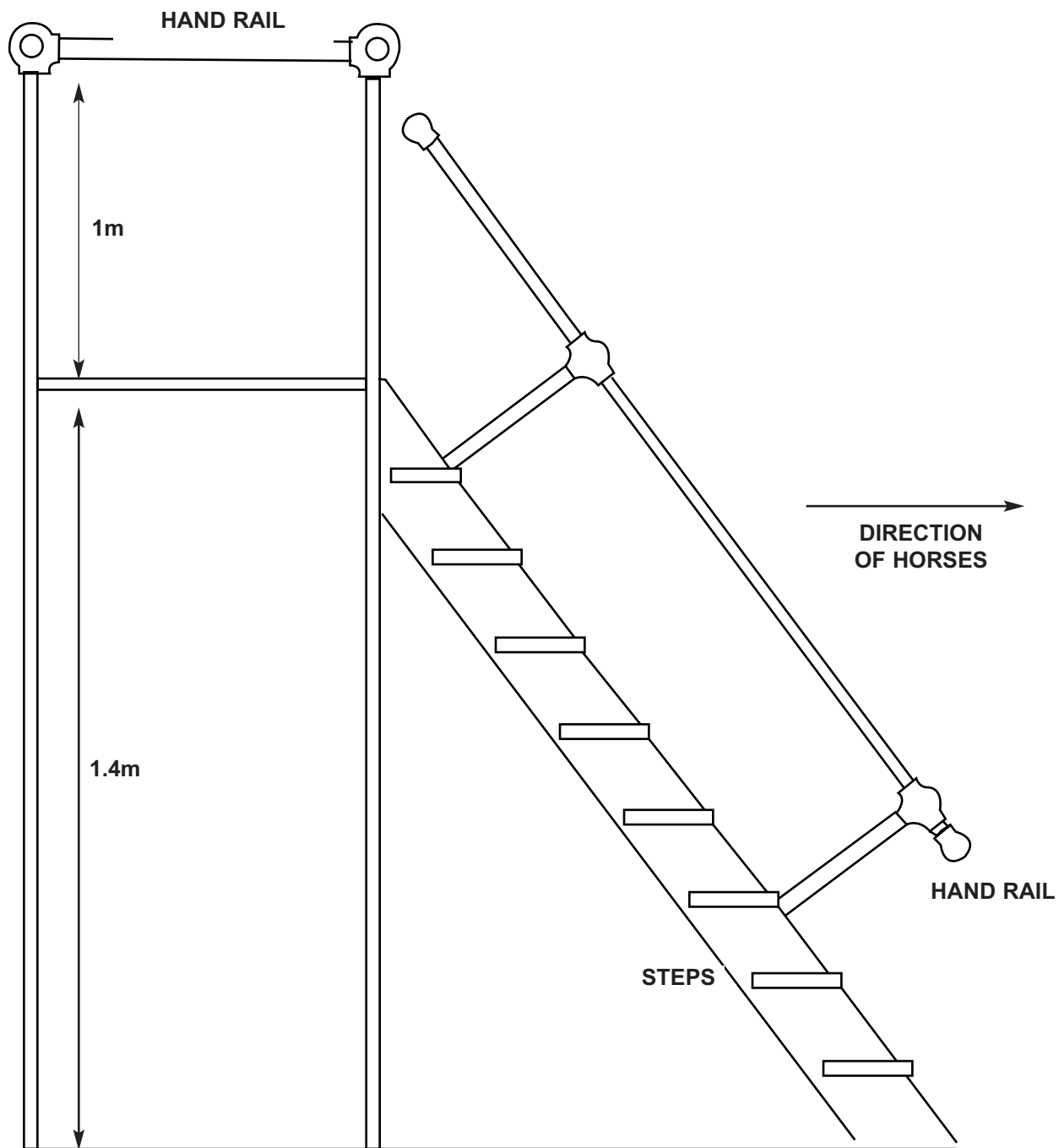

Section 3

OFFICIAL STABLES **COMPLEX**

Section 3: OFFICIAL STABLES COMPLEX

- 3.1 INTRODUCTION
- 3.2 LOCATION
- 3.3 LAYOUT
- 3.4 HORSE BOX PARK
- 3.5 PERIMETER BARRIER
- 3.6 SECURITY ACCOMMODATION
 - Dimensions*
 - Location*
 - Fittings*
 - CCTV Installation*
- 3.7 SPECIFICATION FOR LOOSE BOXES
 - Construction*
 - Internal Surfaces*
 - Internal Fittings*
 - Tack Boxes*
 - Full-Grilled Boxes*
 - Power Points*
- 3.8 BARN STABLING
- 3.9 ANCILLARY REQUIREMENTS
 - Sampling Unit*
 - Veterinary Treatment Box*
 - Lighting*
 - Water*
 - Toilets*
 - Stores*
 - Washing Down*
 - Drying Room*
 - Sand Bath*
 - Midden*
 - Communications*
 - Notices and Signs*
 - Emergencies*
 - Fire Precautions*
- 3.10 CANTEEN AND OVERNIGHT ACCOMMODATION FACILITIES
 - Location*

Section 3: OFFICIAL STABLES COMPLEX

3.1 INTRODUCTION

For the Stables Complex, it will be necessary for the following factors to be taken into account:

- British Horseracing Authority Rules and General Instructions;
- planning requirements;
- building regulations;
- local bye-laws;
- fire regulations;
- The Health and Safety at Work Act (1974).

In the early planning stages it will be necessary for the Racecourse Executive to consult various bodies, including the British Horseracing Authority Racecourse Department, Veterinary Department and Integrity Services and Licensing Department, as well as the Health and Safety Executive (HSE).

No attempt has been made in this section to cover the use of stable complexes for activities outside horseracing under the British Horseracing Authority's Rules.

3.2 LOCATION

For reasons of time and convenience it is recommended that a Stables Complex be sited next to or near the Pre-Parade (and/or Parade) Ring, as well as to the Saddling Boxes.

Provision must be made for mains water, good drainage/sewerage and an adequate supply of electricity. The site, as well as all walkways etc., must be suitably illuminated to comply with Health and Safety at Work requirements. A substantial supply of hot and cold water will also be required. There must always be provision for sufficient warm/cold water for the washing down of horses to last for the duration of a race day.

3.3 LAYOUT

In designing the layout of the Stables Complex (see Photo 3.A) the number of boxes required should be a primary consideration. This should be equal to the maximum number of runners possible on any given race day, when calculated against the Safety Factor for each of the races taking place. Furthermore, Course Executives should consider the potential for additional boxes, in order to cater for horses that need to be stabled overnight. This is of particular importance where courses stage racing on consecutive days. Care must be taken to ensure that there is always sufficient space within the complex for the movement of horses and emergency vehicles. Two suggested layouts can be found at Figs. 3.A/.B.

The main entrance must be wide and high enough to admit vehicles carrying paper bedding or shavings, fire appliances and, potentially, horse boxes.

Emergency gates/exits must be provided in enough number to comply with fire regulations. Such exits must be wide enough to admit fire appliances. Any further access points should be minimised, as they may require additional manning (with British Horseracing Authority Stable Security Officers), thus resulting in extra Course Executive costs.

A key consideration when considering layout is the requirement to provide the BHA Integrity Services & Licensing Department with good and clear CCTV coverage of the entire yard, including the main entrance and emergency exits. All CCTV installation points must be agreed by the Integrity Services & Licensing Department. Further guidance for this can be obtained from the Security Operations and Projects Manager at the British Horseracing Authority (Tel: 020 7189 3875).

3.4 HORSE BOX PARK

Access for vehicles to the Horse Box Park should be separated from the routes for the racegoing public's vehicles.

The vehicle approach to the stable complex must be designed so that a constant flow can be maintained without affecting main carriageways. The approach road surface must be made of either tarmac or concrete.

Loading and unloading ramps (see Fig. 3.C for side and rear loading ramp specification) for several vehicles must be provided, adjacent to the entrance. The area must be well illuminated to enable horse boxes to load and unload at night. The size and siting of the loading ramp must be agreed with the Racecourse Department (in line with BHAGI 7.1) and advice can be given with regard to catering for rear loading horseboxes. Any such advice will be site-specific.

The Horse Box Park must be segregated from public car parks and pedestrians. It should be well drained, with a well maintained concrete or tarmac surface. It must have adequate space for all horse boxes required to service the maximum number of horses at a meeting.

Toilets for male and female box drivers must be provided, as per BHAGI 7.1.

3.5 PERIMETER BARRIER

A perimeter barrier must surround the official racecourse stable yard. The barrier must be a minimum of 3m high and be of a substantial construction.

The barrier must be topped by at least three strands of taut barbed wire (or equivalent), each strand being 15cm apart and supported by metal struts angled outwards at suitable intervals.

3.6 SECURITY ACCOMMODATION

Dimensions

A suitable office must be provided, of minimum dimensions 3m x 2.4m. This office must provide space enough for both the British Horseracing Authority Stable Security Officers and the Racecourse Stable Manager. The office will also be used by the Stable Manager to supply the keys for the stables, where applicable.

Location

The office should be sited on the left-hand side of the stable entrance, so as to provide good visibility of the approach to the stable yard, main gate and entrance area.

Fittings

The office must be kept clean and appropriately furnished, with enough counter-space to allow the relevant officials to complete their paperwork (this will include the Stable Security Officers, Stable Manager and Veterinary Officers). The office should be well-publicised by prominent signage, be well lit, and properly heated. It must have a telephone for communications with the Weighing Room and for making and accepting outside calls. As per BHAGI 7.1, it will also require an Emergency Toolkit. There must also be sufficient space to contain the colour CCTV control system and monitor, which should be sited in an accessible and lockable unit. Some form of floor covering is also necessary.

See BHAGI 7.1 (paragraph 3 refers).

CCTV Installation

All racecourse stables must have a digital colour CCTV system installed in line with the requirements of the British Horseracing Authority Integrity Services and Licensing Department. Consequently, racecourses must consult with the Integrity Services and Licensing Department (details of which are as listed in 3.3 above) with regard to camera specification, coverage, siting and picture storage requirements before any CCTV equipment is installed. Whilst racecourses may be able to approach the Levy Board for funding of the provision of the cameras, the racecourse will be responsible for their provision and maintenance.

See BHAGI 7.1 (paragraph 15 refers).

3.7 SPECIFICATION FOR LOOSE BOXES

Construction

All new stables must:

- be a minimum of 11.15 sq metres (120 sq ft), with no side less than 3m (10 ft) long. A proportion of stables must be a minimum of 13 sq metres (140 sq ft) to cover for 'overnight' or larger horses. Where space is at a premium, the size of new boxes may be varied at the discretion of the Racecourse Department;
- have half doors, capable of being held open by retaining hooks, in which the lower half cannot be opened if the top half is closed. The half doors must have flush (wooden or metal) internal surfaces. Any part of the door (inside or out) which may be chewed must be protected by a correctly fitted integral metal strip or sheet;
- have draw bolts on the top and bottom door or kick fasteners (where relevant), except for in Full-Grilled stables;
- be at least 3m high at the eaves unless a lesser height, depending on circumstances (e.g. planning permission difficulties), is agreed with the Racecourse Department;
- be well ventilated with ridge vents;
- have a roof overhang of at least 1m. Where space is at a premium, the overhang dimensions may be varied at the discretion of the Racecourse Department;
- have window surrounds that must be finished to the same specification as the interior walls. Windows must be effectively protected, with minimum rebates;
- have effective physical separation between adjacent stables;
- have rubber or concrete floors that drain freely. Any racecourse intending to construct stables built principally from wood must obtain the prior approval of the BHA Racecourse Department.

See BHAGI 7.1 (paragraph 7 refers). See also Photo 3.B.

Internal Surfaces

All walls must be solid, with smooth surfaces and an impervious finish. The junction of the walls and the floor must be effectively sealed. Any part of the stables that is liable to be chewed must be protected by a correctly fitted metal strip or sheet.

All internal surfaces must be capable of being cleaned and disinfected as required by BHAGI 7.2.

Internal fittings

No internal wall-mounted fittings (including mangers) are permitted other than a tie ring. Any electric wires/fittings, internal or external, must be waterproof and either beyond a horse's reach or securely protected to prevent the possibility of chewing.

Tack Boxes

Tack boxes must be provided with lighting and locks. Tack boxes or kit lockers within individual stables are not permitted. Tack boxes can be

incorporated as part of a range of boxes. The approximate size of tack boxes should be 1.8m x 1.2m.

Full-Grilled Boxes

At least 2 of these are required, in line with BHAGI 7.1.

Power Points

These must be installed at regular intervals around the yard for the operation of machines (such as aerosol generators) for disinfecting purposes.

3.8 BARN STABLING

The British Horseracing Authority Veterinary Committee has advised that Barn Stabling WILL NOT be considered at new build racecourses.

3.9 ANCILLARY REQUIREMENTS

Sampling Unit

This must be located within the Stables Complex (see Section 7.1).

Veterinary Treatment Box

See Section 7.2.

Lighting

The stable yard must be floodlit and all passageways well illuminated. All boxes, tack boxes, store rooms, toilets and washing down areas must be illuminated. Additionally, the full-grilled stables or those used overnight must be fitted with individual external switches.

BHAGI 7.1 (paragraph 14 refers).

Water

An adequate hot water supply must be provided at a clearly marked point or points. Any boiler arrangements must be such that the hot water supply remains available throughout the day's racing. This is particularly important at Winter Jump and AWT fixtures. Cold water taps must be installed at regular intervals around the yard.

Toilets

These must be installed for both male and female stable staff.

Stores

Stores must be provided for bedding such as wood shavings, paper bedding, etc.

Washing Down

A washing down area or areas (preferably covered) capable of accommodating at least 3 horses simultaneously must be provided with a good supply of hot and cold water. There must be adequate (e.g. retractable) hosing and good drainage. Consideration should also be given to providing heated boxes for drying horses off.

Drying Room

A drying room may be installed for horse blankets and tack.

Sand Bath

A sand bath may be considered.

Midden

A midden (muck heap) must be provided for soiled bedding. These must be emptied between each race meeting. A tipping trailer can provide a means of avoiding double handling.

Communications

An outside telephone line must be installed in the Security Office, as well as a pay-phone for stable staff in either the stable or canteen area. Telephone communications must be available between the Security Office and the following:

- Weighing Room;
- Clerk of the Course;
- Racecourse Office;
- Veterinary Surgeon's Box;
- main First Aid Post.

There should be a public address (PA) system that covers the whole Stables Complex, as well as the Horse Box Park. This is to be operated from the Security Office and will incorporate a fire warning device.

The telephone numbers of Vets, Doctors, etc. are to be clearly displayed in the Security Office, and a full First Aid Box is to be kept in the Stable Manager's Office.

Notices and Signs

Such notices and signs as are required by the BHAGIs must be installed. All boxes must be numbered, and stores/ancillary facilities clearly signed.

See BHAGI 7.1.

Emergencies

Heavy duty tools must be available for fire and/or other emergencies in order to break down stable doors etc. without delay.

Fire Precautions

In consultation with the Fire Authorities, adequate fire alarms, hoses, fire extinguishers and fire buckets must be installed, together with appropriate fire exit signs. Hydrants must be clearly marked.

See BHAGI 7.1.

3.10 CANTEEN AND OVERNIGHT ACCOMMODATION FACILITIES

Location

The canteen and overnight accommodation facilities must be immediately adjacent to the Stable Complex, so that stable personnel can be close by in the event of an emergency.

For fittings and facilities required for the above facilities, see BHAGI 7.4.

'Dorm-style' overnight accommodation for horse attendants, travelling head lads etc. is not acceptable.

Note: Should the overnight hostel facilities at a racecourse not be available to or suitable for stable staff wishing to change during the day time, alternative 'day changing facilities' (showers, lockers etc.) must also be provided within the racecourse premises.

Fig. 3.A

Fig. 3.B

Fig. 3.C

Photo 3.A Official Stables Complex – Warwick

Photo 3.B Loose Box – Southwell

OFFICIAL STABLES COMPLEX 'PLAN A'

FIG. 3.A

This plan ensures that all boxes are in view of the Security Office. It will require at least 1.5 hectares of ground plus about 1 hectare for a box park but will be spacious with more than adequate space for sand baths and similar amenities.

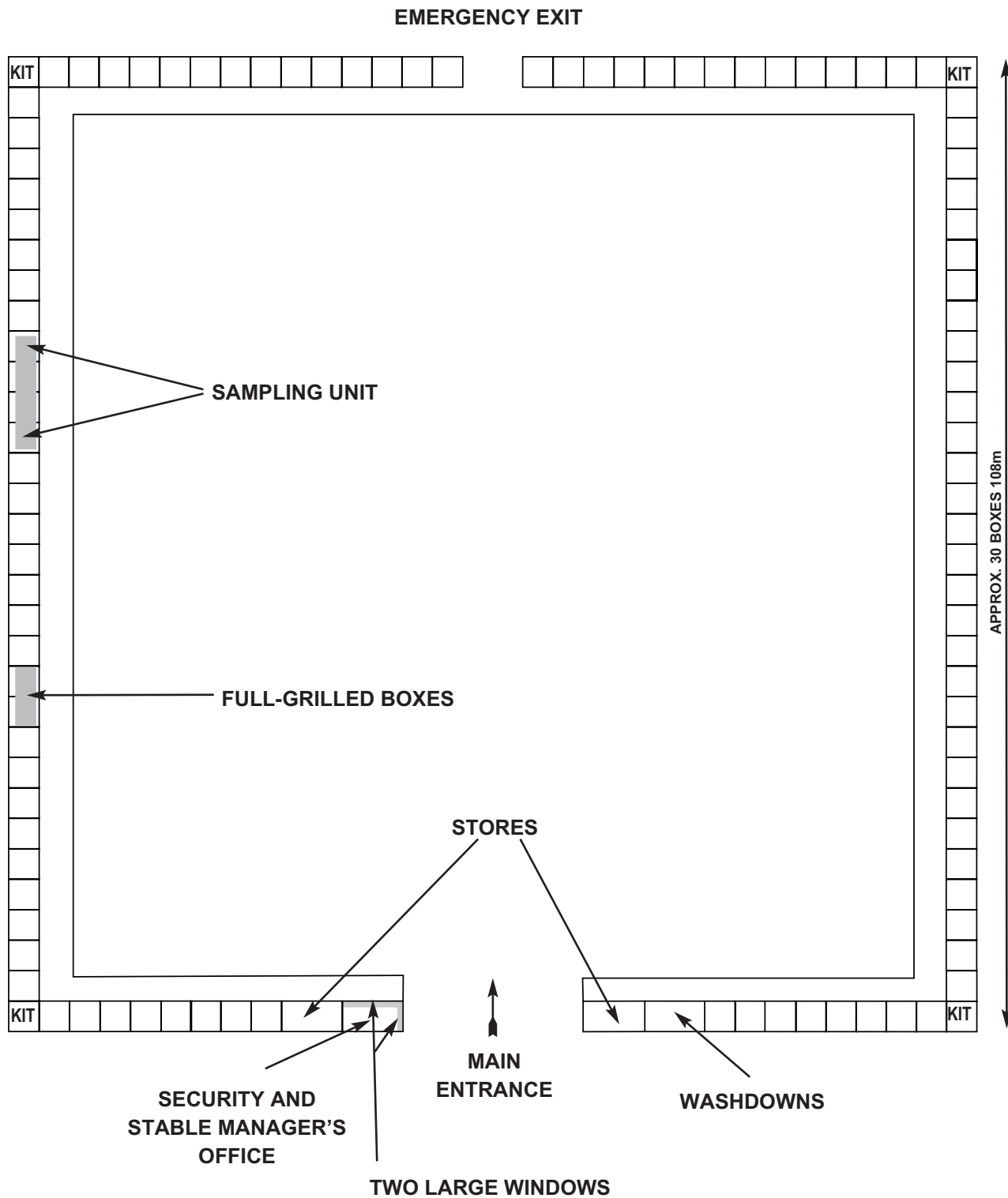

OFFICIAL STABLES COMPLEX 'PLAN B' FIG. 3.B

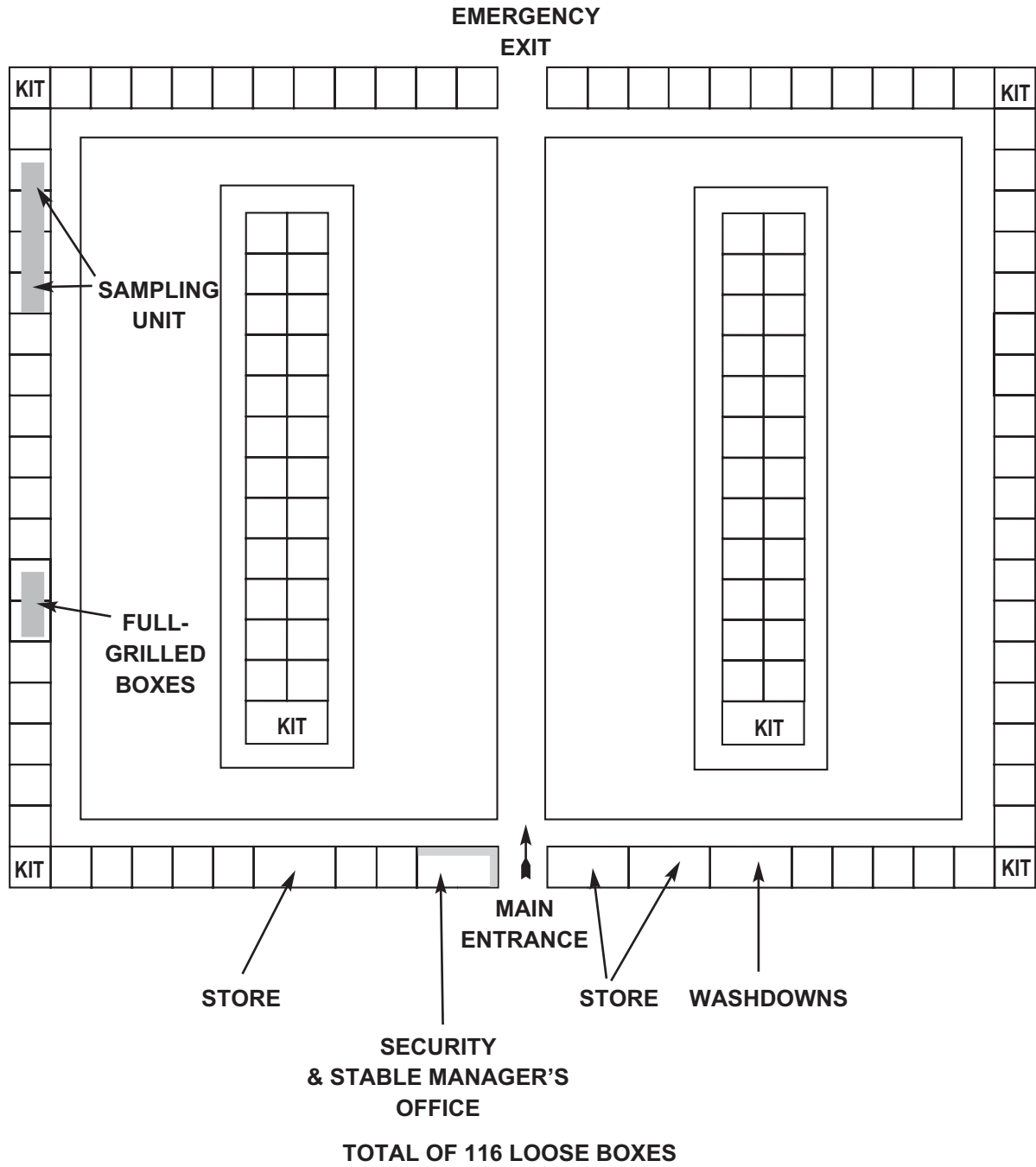

LOADING/UNLOADING RAMP
FIG. 3.C

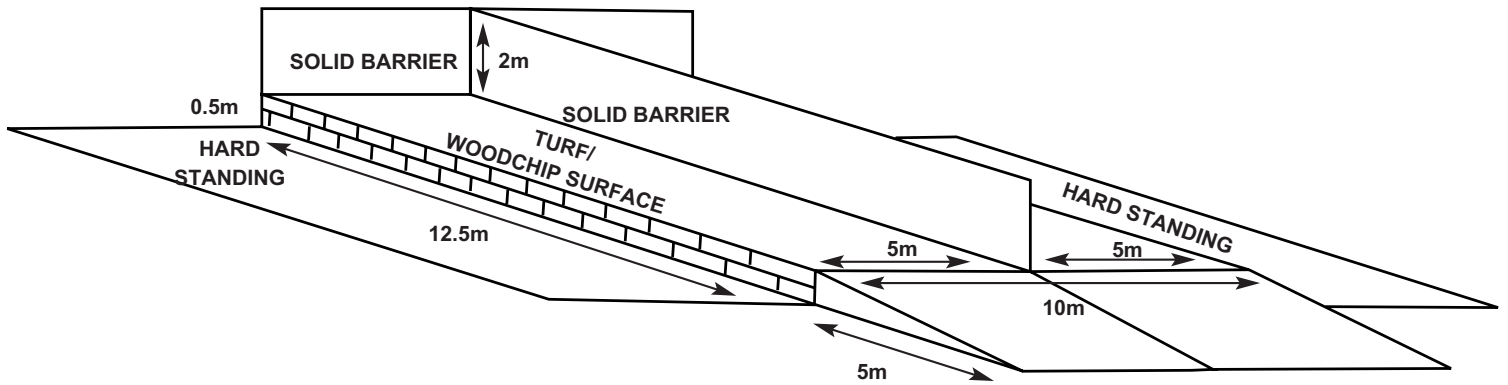

Note: A loading ramp for rear loading horseboxes must also be provided, the platform of which should be 10m x 5m. The platform should be at a height of 0.5m, with a ramp descending to ground level over a distance of 5m. There must also be a solid barrier, 2m high, along one of the 10m and one of the 5m sides.



Photo 3.A Official Stables Complex – Warwick



Photo 3.B Loose Box – Southwell

Section 4

THE PADDOCK

Section 4: THE PADDOCK

4.1 SADDLING BOXES

Location

Dimensions

Fittings

4.2 PRE-PARADE RING

Location

Dimensions

Layout

Fittings

4.3 PARADE RING

Location

Dimensions

Layout

Fittings

4.4 HORSEWALKS

4.5 UNSADDLING ENCLOSURE

Section 4: THE PADDOCK

4.1 SADDLING BOXES

Location

The Saddling Boxes are to be located in (or adjacent to) the Pre-Parade Ring (see Fig. 4.A). There are to be enough to cater for the maximum number of runners, as determined by the Safety Factor.

Dimensions

Saddling Boxes must be not less than 2.4m wide x 3m long, with a clear height of 3m. They are to be constructed of materials that are easily cleanable, with an impermeable finish.

Fittings

Saddling Boxes must have hard level floors, with partitions high enough to prevent interference from neighbouring horses (see Photo 4.A). 25% of the Saddling Boxes are to have front walls complete with doors.

One of these closed boxes may serve as a Farrier's Box, containing central lighting and water, as well as an electrical supply if possible. Closed boxes are to have a non-slip floor, draining to the door.

A kicking surface must be provided on the rear sides and the back wall of all boxes. This is to be of a shock absorbing, rubberised and cleanable material, to prevent damage to horses' legs, as well as to prevent plates from spreading.

See BHAGI 8.4.

4.2 PRE-PARADE RING

Location

Adjacent to the Parade Ring (see Fig. 4.A).

Dimensions

A suitable size to accommodate the numbers of horses that are likely to use it. The BHA Inspectorate can provide guidance in this regard.

Layout

The Pre-Parade Ring will incorporate the following facilities:

- horsewalk from unloading area/overnight stabling;
- covered area for 'Arm Band Official';

- Saddling Boxes;
- box for farrier;
- spectator viewing;
- non-slip, rubberised horsewalk to Parade Ring.

Fittings

The Pre-Parade Ring is to be bordered by a substantial barrier at least 1.22m high. The Racecourse Executive is responsible for installing any additional barriers or rails which it believes are necessary to protect the public from the horses. The horse walk surface of the Pre-Parade Ring must be of rubberised and non-slip material (see Section 4.4).

See BHAGI 8.4.

4.3 PARADE RING

The Parade Ring should provide an area in which to parade all horses involved prior to the start of the race in front of officials, owners, trainers, media and members of the public. It also serves as the area for jockeys to mount horses, and may be used to provide an unsaddling enclosure where the prize giving ceremony can be carried out in front of the public. In this case, a presentation public address (PA) system should be provided and a presentation rostrum should be considered.

Location

The position of the Parade Ring (see Fig. 4.A) should take into account the following factors:

- the position of the Weighing Room entrance;
- the proximity to the grandstand, in order that racegoers may reach the viewing terraces easily;
- the possibility of using the rear elevation of the grandstand for additional viewing areas;
- access from the Pre-Parade Ring;
- access to the Course;
- ease of access for Officials.

Dimensions

The Parade Ring horsewalk should be at least 2m wide and must be made of a non-slip, shock absorbing, rubberised material. The Ring must have a minimum bend radius of 12m, allowing 4.83m per horse for the maximum number that would be expected with agreed Safety Factors. If the Winner's Enclosure and/or Unsaddling Enclosure are to be incorporated into the Parade Ring, the dimensions of the Parade Ring will need to be increased over and above these specifications to reflect this dual purpose.

Layout

The Parade Ring will incorporate the following facilities:

- access to the Course;
- access to Weighing room;
- access to Pre-Parade ring;
- parade horsewalk;
- Winners Enclosure;
- spectator viewing;
- disabled persons viewing terrace;
- owners and trainers viewing area;
- press viewing area;
- television commentator position;
- television camera position;
- PA system.

Horse entrances and exits to the Parade Ring must be a minimum of 2.4m wide between safety rails.

Access to the Parade Ring must be through a restricted number of signposted access points (1m wide), allowing for stewards, officials, owners, trainers and press. A sign indicating the minimum age for those permitted to enter the Parade Ring, as well as a clear reference to any age groups restricted to entry only with an accompanying adult, must be erected. Children under the age of 12 are to be excluded from the Parade Ring, with those aged 12-16 permitted only when accompanied by an adult. However, some racecourses prefer to limit entry, accompanied or otherwise, solely to those aged 16 or over.

Fittings

The Parade Ring must be bordered by a double safety rail, consisting of an approved running rail adjacent to the horse walk and an outer, independent crowd barrier. The minimum spread of this double barrier should be 1m, and all sharp corners should be padded. The minimum height of the inner rail must be maintained at 1.22m.

The barrier between viewing areas and the Parade Ring must incorporate some form of permanent barrier fencing, in order to prevent children and other members of the public from ducking under the rail. Where a large concentration of people is expected at a barrier, consideration must also be given to designing the barrier in line with the relevant crush barrier standards (see *Guide to Safety at Sports Grounds* ISBN no.: 0-11-300095-2).

Where there are more than five viewing steps, crush barriers will be required – liaise with Local Authority for relevant statutory regulations. Construction of the viewing steps should take into account overall and individual unit stability, as well as long-term weather resistance/durability. In tandem with any other risk-reducing procedures, Course Executives also need to consider the

installation of additional fencing, rails or barriers in line with risk management best practice.

There must be an appropriate gap of at least 1.5m between the Parade Ring rails and the horsewalk surface, to best ensure that the public and horses are suitably distanced. This also enhances the public's view of the horses.

Generally, the central area is turfed. This forms an area in which Officials, Owners and Trainers can congregate, as well one that Jockeys can use for mounting. Consideration should be given to the size of the central area, related to the maximum Safety Factor at each course. It should be noted that, increasingly, horses are owned by groups/syndicates, many of which will attend when a horse runs, thus resulting in greater pressure on space in the central area.

The exit route from the Parade Ring must be marked with guide rails. Gaps in these rails must exist, be marked/manned for access, and be padded where appropriate.

See BHAGI 8.4.

4.4 HORSEWALKS

The horsewalks that lead from the Stables to the Pre-Parade Ring/Saddling Boxes, from the Saddling Boxes to the Parade Ring, and from the Parade Ring to the Course must be constructed from non-slip, shock absorbing, rubberised material as used in the Parade Ring itself.

The surface must have suitable drainage. Any kerbs installed to retain non-slip rubberised materials must be flush with the surface of the horsewalk and the soil base of any surrounding turf.

4.5 UNSADDLING ENCLOSURE

The Unsaddling (or 'Winners') Enclosure must provide sufficient space to accommodate first, second, third and fourth placed horses, as well as their owner(s), trainer, horse attendant and possibly medical or veterinary representatives. Stall partitioning is not recommended. A designated unsaddling area must also be provided for unplaced horses (see Fig. 4.A).

Signs should be placed around the Unsaddling Enclosure to identify the first, second, third and fourth placed horses. Any other signage should be kept to a minimum.

The Enclosure must be separated from the rest of the Parade Ring by a fence with a double safety rail. A position or rostrum should be considered for an auctioneer (for use following selling races), as should an outlet for a CCTV monitor and a PA installation. In addition, a raised presentation dais may be provided for prizegivings.

See BHAGI 8.4.

Fig. 4.A

Photo 4.A Saddling Boxes – Musselburgh

HYPOTHETICAL DIAGRAMMATIC LAYOUT OF THE PADDOCK
FIG. 4.A

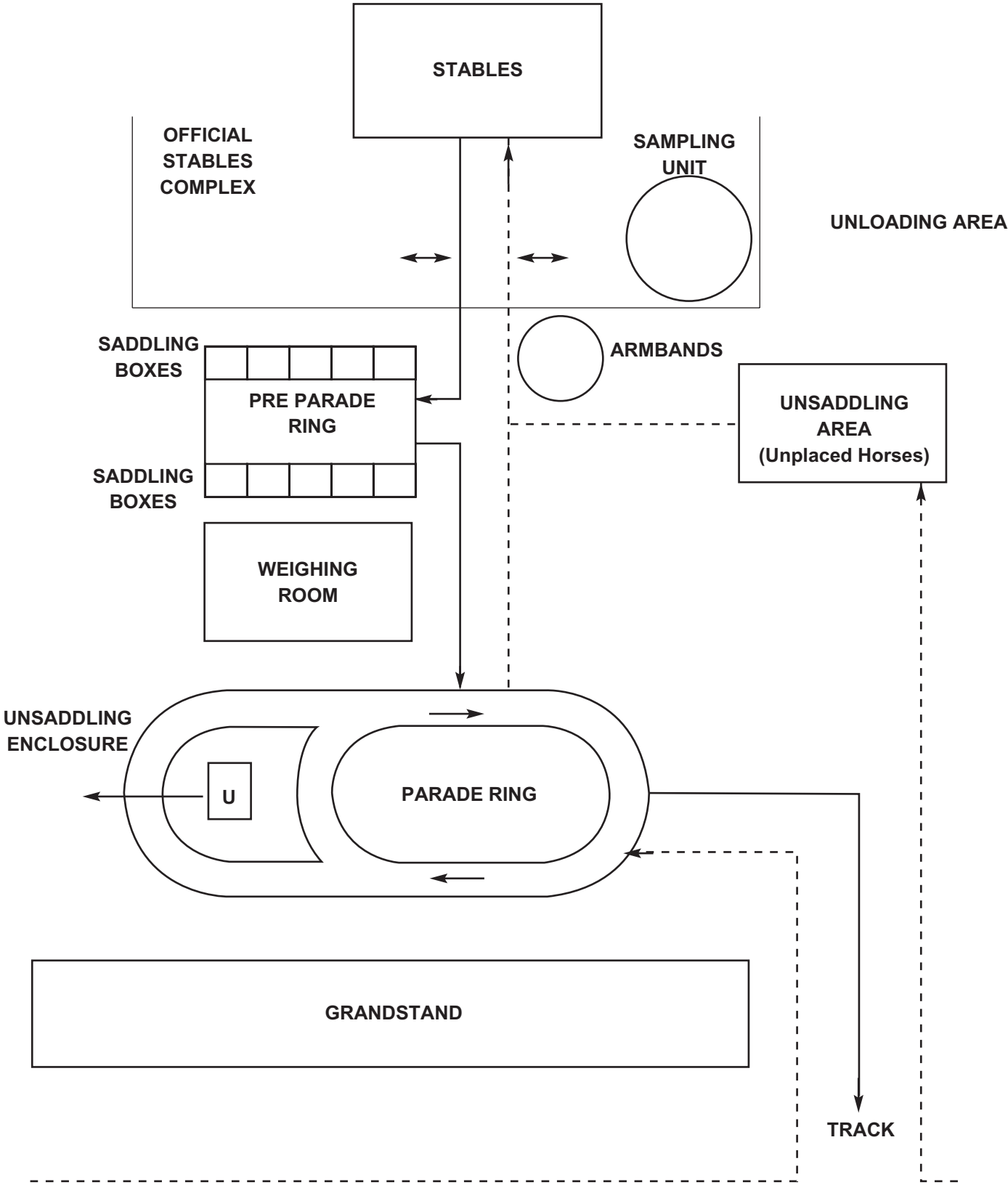



Photo 4.A Saddling Boxes – Musselburgh

Section 5

WEIGHING ROOM **COMPLEX**

Section 5: WEIGHING ROOM COMPLEX

5.1 LAYOUT

5.2 WEIGHING ROOM WORK AREA

Location

Dimensions

Fittings

5.3 SCALES

5.4 DECLARATIONS ROOM/COUNTER/DESK

Location

Dimensions

Fittings

5.5 BROADCAST OFFICE

Location

Dimensions

Fittings

5.6 HANDICAPPER'S ROOM

Location

Dimensions

Fittings

5.7 CLERK OF THE COURSE'S ROOM

Location

Dimensions

Fittings

5.8 STEWARDS' ROOM

Location

Dimensions

Fittings

5.9 JOCKEYS' CHANGING ROOMS

Location

Dimensions

Fittings

5.10 VALETS' ROOM

Location

Dimensions

Fittings

- 5.11 JOCKEYS' REST ROOM
 - Location*
 - Dimensions*
 - Fittings*
- 5.12 PUBLIC ADDRESS INSTALLATION
- 5.13 JOCKEYS' MEDICAL ROOM
- 5.14 PRESS INTERVIEW ROOM
- 5.15 GENERAL MEDIA FACILITIES

Section 5: WEIGHING ROOM COMPLEX

5.1 LAYOUT

The Weighing Room Complex must include the following:

- Scales;
- Declarations Desk;
- Broadcast Office;
- Changing Rooms (Male and Female);
- Valets' Room;
- Stewards' Room;
- Jockeys' Rest Room;
- Press Room;
- Jockeys' Medical Room;
- a room for use by Medscreen (Jockeys' drug testing), or a parking space in the vicinity of the weighing room to accommodate their mobile unit;
- smoking area (assuming space permits) – this should be kept external but secure, so that members of the public cannot approach jockeys (e.g. a small fenced off area with emergency egress only).

Optional:

- Handicapper's Room;
- Clerk of the Course's Room.

The location of all these rooms in relation to one another is important (For a possible layout, see Fig. 5.A).

All entrances (other than the main entrance) must be secured during racing. If these are to be kept open, then they must be staffed by racecourse staff.

5.2 WEIGHING ROOM WORK AREA

Location

The Weighing Room work area must have a central position within the complex. It must have the Declarations Counter, Handicapper's Room (optional, providing sufficient room is available in the Stewards' Room) and Broadcast Office adjacent or close to it. Noise levels in and around the work area can be high during racing and, as such, soundproofing/acoustics must be investigated, to ensure an appropriate environment.

Dimensions

The dimensions for a Weighing Room work area (i.e. the area behind the rail) are 7.5m x 7.5m. The combined minimum dimensions for the Weighing Room work area and Weighing Room Complex entrance/concourse are 6m x 10.8m.

Fittings

Behind the rail and facing the scales must be a desk or table with a fully adjustable chair provided for the Clerk of the Scales. This table and chair should be positioned with a commanding view of the entrance door and the door to the Jockeys' Changing Rooms. A table and chairs should also be provided for use by other Officials (such as a Judge and Starter). The table for the Clerk of Scales must be of sufficient size to accommodate the scales desk unit, a laptop computer, a printer, and general paperwork. The scales must be set back at least 1.5m behind the rail, and in such a way as to prevent jockeys from going directly into the Changing Room without passing the Clerk of the Scales.

A CCTV monitor that can be controlled by the Clerk of the Scales should be provided near to the Clerk of the Scales' desk. An external ROCS radio aerial must be installed, in order to ensure a clear signal is available from all racecourse starts. There should be sufficient electrical sockets available for use by BHA Officials: 6 for the Clerk of Scales (to include scales, wall display, ROCS radio, laptop, printer, etc.) and 2 each for the Judge(s) and Starter(s).

Other facilities that must be supplied are:

- a notice board displaying the names of 'Acting Stewards' and the 'Handicapper Present';
- a table on which the Number Cloth Official can display the numbers;
- an accurate clock that can be viewed by the Clerk of the Scales;
- a television monitor that can be viewed by the Clerk of the Scales;
- external/internal telephone lines;
- adequate heating and lighting;
- a notice board displaying, for example, the information on the Overnight Declaration of Jockeys;
- CCTV coverage of the Weighing Room (location and siting to be agreed with the Integrity Services & Licensing Department);
- security to the entrances of the Weighing Room and to the Jockeys' Changing Rooms.

The Weighing Room Security CCTV system should be kept secure within a lockable cabinet. The system will be operated by the Weighing Room Security Officer when he commences duty. The CCTV tapes must be stored for a period of 28 days, together with the recording register as maintained by the Weighing Room Security Officer. Tapes may be over-recorded after this time.

See BHAGI 8.3.

5.3 SCALES

Electronic scales are to be provided in the Weighing Room and must have been approved by the British Horseracing Authority (see Photo 5.A).

These can offer additional services such as a public display unit outside the Weighing Room Complex, as well as a print-out of every weight recorded. The power supply to the scales should be connected to the emergency generator circuit (or an uninterruptible power supply unit) and should be surge protected.

5.4 DECLARATIONS ROOM/COUNTER/DESK

Location

This room/counter must be situated close to the central Weighing Room work area. It should be positioned so that the Declarations Clerk is able to communicate by sight with the Clerk of the Scales whilst not impairing the flow of persons in and around the Weighing Room.

Dimensions

If a separate room is being provided it must have minimum dimensions of 1.8m x 2.4m. Alternatively, this may be a long and open counter on which the declarations pages can be laid.

Fittings

If a separate room is used, this will require a table with 2 chairs. There should be a large window looking out onto the Weighing Room work area so that the Declarations Clerk can see and communicate with the Clerk of the Scales. The room must be clearly marked. If an open counter is used, a chair will be required. A fax machine and suitable telephone link must also be provided.

5.5 BROADCAST OFFICE

Location

The Broadcast Office must be situated so that it is in both viewing and hearing distance of the Clerk of the Scales. It should be noted that heavy equipment has to be transported to and from this room.

Dimensions

The room will usually house 2-3 people but may have to accommodate up to 6 as appropriate. As such, the dimensions for a Broadcast Office must be no less than 4m x 3m.

Fittings

Work benches should be fitted, on to which the broadcasting equipment can be placed. The location and dimension of these benches should be no less than 70cm from front to back and 84cm high. At least two chairs – preferably swivel chairs – should be provided. As a minimum, there should be twelve 13 amp switch socket outlets. Detailed advice on the layout and design can be

given by an integrity service provider. There must also be telephone links with the Stewards' Main Viewing and Judge's Boxes.

5.6 HANDICAPPER'S ROOM (Optional)

Location

If not accommodated within the Stewards' Room, the Handicapper's Room should be sited close by.

Dimensions

This room should not be less than 1.8m x 2.4m in size.

Fittings

A desk and a chair are required. A minimum of 4 power points should be installed.

The office should have adequate heat and light. It should be clearly marked as being for the sole use of the Handicapper present, and must be lockable.

5.7 CLERK OF THE COURSE'S ROOM (Optional)

Location

This room can be located anywhere within the complex, as long as the Clerk of the Course can readily communicate with the Clerk of the Scales.

Dimensions

There are no specific dimension requirements, but the room should be large enough to accommodate the fittings outlined below.

Fittings

A desk and a chair are required, as well as a telephone with both internal and external line options.

The Clerk of the Course is an employee of the Racecourse Executive. The BHA recommends direct consultation with the individual(s) concerned, in case that there should be additional (or fewer) requirements beyond this basic template.

5.8 STEWARDS' ROOM

Location

The Stewards' Room must be situated close to the Clerk of the Scales and within the Weighing Room Complex.

Dimensions

The Stewards' rooms must be big enough to enable an enquiry involving up to a dozen witnesses. A room of not less than 6m x 5m is required. A small ante-room (in which witnesses can wait while waiting to attend a Stewards Enquiry) may also be considered.

Fittings

The Stewards' Room must be properly soundproofed, ventilated and, if needs be, air conditioned and/or heated. It is essential that the Stewards' Room is well lit, and that people cannot see into the room. A desk must be provided behind which the Stewards and the Stipendiary Steward can sit. It is preferable to have a separate desk for the Stipendiary Steward. The main desk must feature sufficient room for 2 laptop computers, 2 printers and a tape machine, as well as room to seat a shorthand writer. At least 7 chairs should be provided. Hooks for the hanging of coats etc. are required.

The Stewards' Room must be equipped with shelves or tables for up to four integrity service monitors (minimum requirement 28"), positioned so that all persons present in the Stewards' Room have a clear and unobscured view of them. The service provider will specify the connections for these monitors, as well as for a Stewards' talk back unit and electrical pointer, which the integrity service provider will install on racedays. This will enable a Stipendiary Steward to conduct two-way conversations with the Mobile Control Room (MCR) Operator whilst viewing the screens. Every racecourse providing a Closed Circuit Television (CCTV) Service must have a separate television set for outside broadcast and CCTV monitoring. It is essential that a separate outside broadcast television is provided at those courses covered by Network Broadcast.

The service provider will require a minimum of four 13 amp switch socket outlets, the location of which they will specify. A total of ten should be installed for other electrical equipment that may be present in the Stewards' Room, such as a CCTV, off-air TV, photocopier and fax machine.

A direct external telephone line is required. This telephone line will be broadband internet enabled, and the equipment will need to be installed by or on behalf of the BHA, for its Officials to use. A network link and fallover network link, using Ethernet cabling, must be installed between the Stewards' Room and Photofinish Installation, in order to allow for electronic return of the official result through the provided internet connection. The termination in the Stewards' Room should be sited as close as possible to the external telephone line, as an RJ45 terminal.

See BHAGI 8.1.

The Stewards' Room must have a telephone, with both internal and external line options, that can be switched off easily when an enquiry is underway. A three-way telephone system option must also be available for the Stewards to

communicate with each other from their various positions immediately after a race. This telephone should be placed in an accessible position close to the video screens. A shelf should also be provided for the provision of the amplification equipment, in order to alert jockeys of their requirement to attend enquiries.

A letter box and meshed catching basket should be situated on the inside of the Stewards' Room door.

See BHAGI 8.1.

Note: For details of Stewards' head-on and side-on viewing positions, see Section 10.

5.9 JOCKEYS' CHANGING ROOMS

Location

The Jockeys' Changing Rooms must be situated such that when jockeys return after a race they have to pass directly in front of the Clerk of the Scales before entering these rooms. This helps to avoid a situation where jockeys might fail to weigh in.

Dimensions

The size of the Jockeys' Changing Rooms depends on the size of the racecourse and the maximum number of runners (Safety Factor) in any one race, but it must ultimately be able to accommodate the maximum number of jockeys on any raceday. The male Jockeys' Changing Room should be considerably larger than its female counterpart, with standard dimensions of no less than 6m x 12m.

Fittings

Both male and female Jockeys' Changing Rooms must have adjoining toilet and washing areas. Showers must be installed, with a minimum of three in the male Jockeys' Changing Room, and two in the female Jockeys' Changing Room. These should be fitted with wash basins. A sauna is normally expected to be available for use by the jockeys.

Benches must line the walls and work tops must be provided in the centre of the room (see Photo 5.B). Other necessities are saddle racks, clothes hooks, a sufficient supply of lead weights, mirrors, a notice board and an accurate clock. Both male and female Jockeys' Changing Rooms must have trial scales installed. Ideally, these should be electronic, with appropriate emergency back-up power and surge protection.

The changing rooms must be adequately illuminated, heated and very well ventilated. A number of power points must be fitted, and a suitable internal PA system should be included, so that Jockeys can be given a countdown of

when they need to leave for the Parade Ring and/or when they are needed to attend an Enquiry.

See BHAGI 8.3.

5.10 VALETS' ROOM

Location

This room must be directly connected to the changing rooms.

Dimensions

The room should be no less than 3m x 3.6m with a connecting drying room of 2.4m x 3m.

Fittings

The room must be equipped with a washing machine, industrial tumble dryers, power points and good lighting (see Photo 5.C). There should be a sink with hot and cold running water, a scrubbing board (with the necessary hooks above) and drying racks in the connecting drying room. An access door, which will be locked during racing, must be provided for transferring kit to and from vehicles. The distance between the access door and vehicle parking point should be as short as possible, as heavy equipment has to be transported to and from this area.

5.11 JOCKEYS' REST ROOM

Location

The Rest Room should be located between the male and female Jockeys' Changing Rooms.

Dimensions

The room should have minimum dimensions of 6m x 4m.

Fittings

Comfortable chairs, tables, TV (to include coverage of the day's racing if possible) and refreshments should be available (see Photo 5.D), as well as a small number of bunk beds if requested.

5.12 PUBLIC ADDRESS INSTALLATION

A PA system must be installed throughout the racecourse, so that the public can hear all announcements from the Weighing Room and Judge's Box, as well as all race commentary feeds from the Commentary Box.

Care must be taken not to place loudspeakers where they may interfere with sight lines for Officials or integrity service providers, or where they may 'spook' horses (in the Parade Ring, for example). Installations must comply with Local Authority regulations.

The PA installation must be provided with an independent emergency power supply into the Broadcast Office, which can be immediately switched-in to replace the mains power supply in the event of a failure.

5.13 JOCKEYS' MEDICAL ROOM

See Section 6.

5.14 PRESS INTERVIEW ROOM

Facilities must include a Press Interview Room, with racecourse installed TV monitors and associated cables linked to the MCR. This room will be used by the Press to interview jockeys, trainers, owners, officials etc. The Press Interview Room must have a door to the outside of the building so that members of the Press do not enter through the Weighing Room Complex.

5.15 GENERAL MEDIA FACILITIES

The Weighing Room Complex may also contain the on-course facilities required by the Media over and above the Interview Room in 5.14 above.

The facilities are to include a Press Room (see Photo 5.E) which must:

- be conveniently located for the paddock/unsaddling area;
- have a PA Feed and work stations (including desks, chairs, telephone points and 13 amp power points) for journalists;
- have a photocopier;
- have two televisions (including at least one with text facility);
- a VCR or DVD player;
- have access to a cloakroom and toilets;
- be (preferably) wireless enabled.

Fig. 5.A

Photo 5.A Scales Area in Weighing Room – Ascot

Photo 5.B Jockeys' Changing Room – Ascot

Photo 5.C Valets' Room – Ascot

Photo 5.D Jockeys' Rest Room – Ascot

Photo 5.E Media Centre – Ascot

- H - HANDICAPPERS' ROOM
- B - BROADCASTERS' ROOM
- D - DECLARATIONS ROOM/COUNTER
- S - SCALES

NOTE: In this example the medical room is located elsewhere. See Section 7.

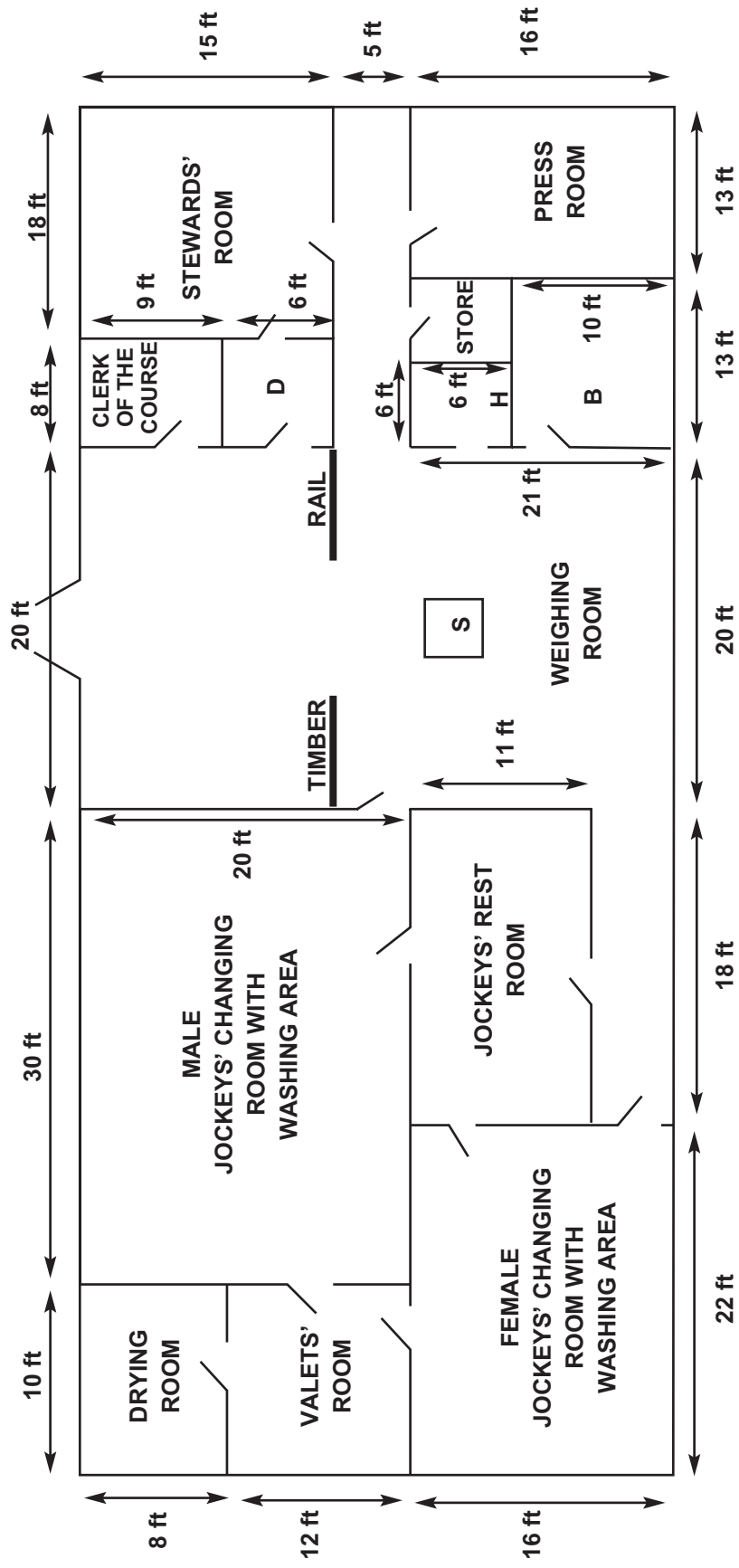

LAYOUT OF A WEIGHING ROOM COMPLEX FIG. 5.A



Photo 5.A Scales Area in Weighing Room (Broadcast Facilities to rear) – Ascot



Photo 5.B Jockeys' Changing Room – Ascot



Photo 5.C Valets' Room – Ascot



Photo 5.D Jockeys' Rest Room – Ascot



Photo 5.E Press Room – Ascot

Section 6

JOCKEYS' MEDICAL **ROOM**

Section 6: JOCKEYS' MEDICAL ROOM

6.1 LOCATION

6.2 DIMENSIONS
Flat racecourses
Jump racecourses

6.3 LAYOUT

6.4 FITTINGS

Section 6: JOCKEYS' MEDICAL ROOM

6.1 LOCATION

The Jockeys' Medical Room (JMR) must be situated within the Weighing Room Complex, with direct access to the Jockeys' Changing Rooms. Ambulances must have unhindered access from the JMR to a main road/exit leading to the nearest hospital.

All areas of the UK are serviced by the Air Ambulance Service. With this in mind, a helicopter landing site must be identified with easy access to the JMR.

6.2 DIMENSIONS

Flat racecourses

The JMR must have minimum dimensions of 6m x 6m.

Jump racecourses

The JMR must have minimum dimensions of 7.2m x 7.2m.

See Fig. 6.A.

6.3 LAYOUT

The JMR must comprise three key areas:

- Examination Room/area;
- WC, en suite;
- an administration area.

Facilities for jockeys must be separated from those provided for the general public and must comprise 2 separate rooms: an examination room (including beds – see Photo 6.A) and an administration area (see Photo 6.B) with integrated WC.

An area in which physios can treat jockeys should also be considered.

A room should be available for the provision of jockey drug testing in the nearby vicinity.

6.4 FITTINGS

There is a minimum requirement of two beds for Flat courses and four beds for Jump courses. All beds must be screened and should have an adjacent table/cupboard. Within the JMR there must be a sink with hot and cold running water, a fridge, and cupboards which can be locked. Where drugs are kept on site, this should be maintained as per government guidelines with a suitable drugs cupboard. A table and chairs are also required.

The whole of the JMR must have adequate heating, lighting and ventilation throughout, as well as a separate outside telephone line. CCTV of the day's racing must be installed so that medical staff can monitor events on the racecourse throughout the day.

The JMR is to be equipped with appropriate First Aid equipment and supplies, as per Annex A to BHAGI 11.2.

Suitable medical arrangements for the public must be provided elsewhere on the course. See HMSO *Guide to Safety at Sports Grounds*. Ref: ISBN 0 11 300095 2.

Fig. 6.A

Photo 6.A Jockeys' Medical Room – Great Leighs

Photo 6.B Jockeys' Medical Room Administration Area – Great Leighs

POSSIBLE LAYOUT OF THE JOCKEYS' MEDICAL ROOM
FIG. 6.A

JUMP COURSES

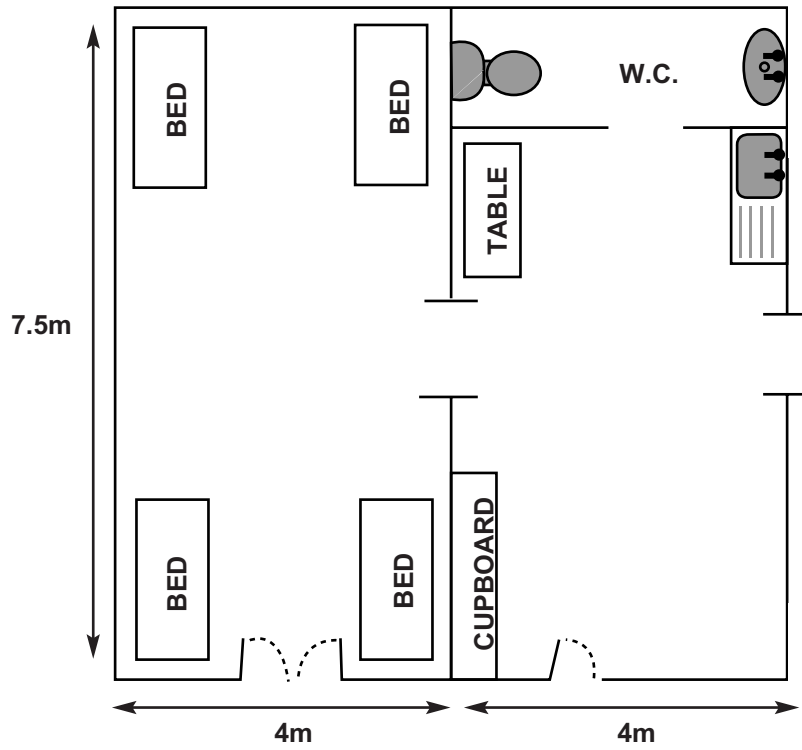

FLAT COURSES

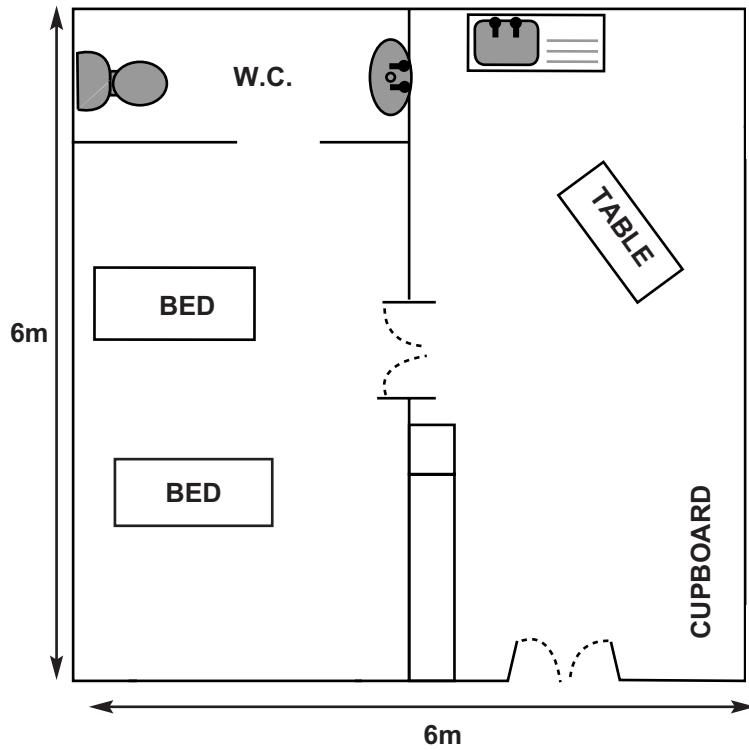



Photo 6.A Jockeys' Medical Room – Great Leighs



Photo 6.B Jockeys' Medical Room Administration Area – Great Leighs

Section 7

VETERINARY **FACILITIES**

Section 7: VETERINARY FACILITIES

7.1 SAMPLING UNIT

Location

Layout

Security

Sampling

Dimensions

Fittings

Equipment

7.2 VETERINARY TREATMENT BOX

Location

Dimensions

Fittings

7.3 OTHER REQUIREMENTS

Section 7: VETERINARY FACILITIES

7.1 SAMPLING UNIT

The Veterinary Officer should expect to fulfil duties in the Parade Ring, the Stewards' Box, the Unsaddling Enclosure, the Official Stables Complex and the Sampling Unit, as well as on the Racecourse itself. This pattern of work has a major influence on the siting of the Sampling Unit.

In the early planning stages, the Racecourse Executive should consult with the BHA Director of Equine Science and Welfare.

As a minimum standard, the Sampling Unit must be constructed and finished to at least the same level as the racecourse stables. It must be capable of being regularly and effectively cleaned and disinfected. The walls must be smooth and impervious, with all timber – including the doors and frames – protected, in order to prevent chewing and thus ensure that the Unit can be readily cleaned. Sampling Units must be sited, constructed and ventilated/heated to ensure that the internal temperature is neither too hot nor too cold. See Section 3 '*Official Stables Complex*' and BHAGI 12.3.

Location

With few exceptions, when the Official Stables Complex is remote from the racecourse, the Sampling Unit must be located in the Stable Yard. This is because:

- it is inside a secure area;
- late passport checking is made easier;
- the environment favours urine collection.

Layout

The Sampling Unit must consist of at least two loose boxes (see BHAGI 12.3, Annex A for a list of those courses requiring four loose boxes), with an enlarged end box and a front overhang. These should be connected to an office and services room. For an example of the current approved layout for 4 box units with access from an office at the back see Fig. 7.A.

Security

The fabric of the building of the Sampling Unit and boxes, including walls and roof as well as doors and any windows, must of suitable robust construction with locks as required, so as to prevent unauthorised access when the unit is locked and unattended.

Sampling

Units must be sited, constructed and ventilated to ensure that the internal temperature is neither too hot nor too cold. A separate (covered) wash down

area must be provided, with good drainage, a non-slip floor, and hot and cold running water, with hose extension. Where possible, Sampling Units should be located in a quiet area of the Official Stables Complex, away from busy walkways. This enables horses to be walked around in calm surroundings before providing a sample.

Dimensions

The dimensions of the loose boxes must be 4.5m x 3.5m. The end loose box must have dimensions of 6m x 4.5m. The height of the eaves above each box must be 3m.

The office area must span the length of three loose boxes (as shown in Fig. 7.A) and have a width of at least 2.5m.

Fittings

The following list of fittings for the Sampling Unit boxes is to be read in conjunction with the minimum requirements specified in BHAGI 12.3.

The loose boxes must have:

- no protrusions or exposed trusses;
- non-slip flooring;
- walls that are smooth and impervious;
- good natural lighting, as well as good artificial lighting, to be out of reach of the horse's mouth and fitted with an internal dimmer switch;
- good ridge ventilation;
- external stable doors with both inside and outside bolts;
- a tie ring;
- a sliding door with screwed-down runner hung on the stable side giving access to the service area;
- a peep-hole or small 2-way mirror inset between the service area and the loose boxes.

In the office and service area (see Photo 7.A) there must be:

- an impervious, easily cleaned floor;
- a lockable external door;
- a small hand basin with hot and cold running water;
- separate low level hot and cold taps over a Belfast sink (for filling buckets);
- corrosion resistant wall mounted hooks for hanging up tack;
- a separate refrigerator and freezer unit, as well as a supply of freezer packs;
- six brackets screwed to the wall to hold urine collectors;
- a telephone link to the Weighing Room;
- a CCTV monitor showing the day's racing.

Work stations must be fitted in the Sampling Unit (see Fig. 7.B). Each work station must be 0.9m wide x 0.6m deep with a document area 1.8m wide.

The worktop must be constructed from a washable, hygienic material (e.g. melamine coated), with each station separated by washable screens. It is essential that a sufficiently well-lit working space is provided, in order to keep each sample's paperwork and packaging clearly separate. In addition, work space is also required for the Sampling Unit Security Assistant's paperwork, as well as for the Veterinary Officer's Daily Record book, passport, laptop computer and printer. Ideally, space for the Veterinary Officer's car should also be provided adjacent to the Sampling Unit.

Equipment

For equipment necessary to the Sampling Unit, see BHAGI 12.3.

7.2 VETERINARY TREATMENT BOX

Location

The Veterinary Treatment Box (VTB) must be in the same location as (but not immediately adjacent to) the Sampling Unit, with convenient, adjacent parking for Veterinary Surgeons and direct access for the horse ambulance and/or recovery vehicle. It must be possible to move a fatally injured horse from the VTB other than solely through the main entrance to the stable yard. If the Official Stables Complex is remote from the racecourse, a VTB must be provided both on the racecourse – probably adjacent to the saddling boxes – and in the Official Stables Complex.

Dimensions

The Veterinary Treatment Box must be 6m x 4.5m in size, and have an anteroom attached.

See BHAGI 12.2.

Fittings

The Veterinary Treatment Box must have:

- a non-slip floor, covered by a seamless rubber material that is screed up the walls to a height of 22 cm;
- drainage to a central internal drain;
- fluorescent strip lights, set into the roof and into the walls at waist level;
- additional lights, one on each side of the box, which can be swung in to illuminate injuries (alternatively, hand-held lights may also be considered).

The anteroom must have:

- secure storage for equipment;
- a sink with hot and cold running water, as well as a hose extension;
- sufficient 13 amp sockets for x-ray equipment;
- endoscope light sources etc.;
- a small refrigerator for ice packs.

7.3 OTHER REQUIREMENTS

A suitable discreet and enclosed area must be designated for the temporary storage of a horse that may have died or been humanely destroyed.

In addition, racecourses may wish to consider the use of padded equine 'stocks' to facilitate the treatment of injuries.

Fig. 7.A

Fig. 7.B

Photo 7.A Sampling Unit – Ascot

FIG. 7.A

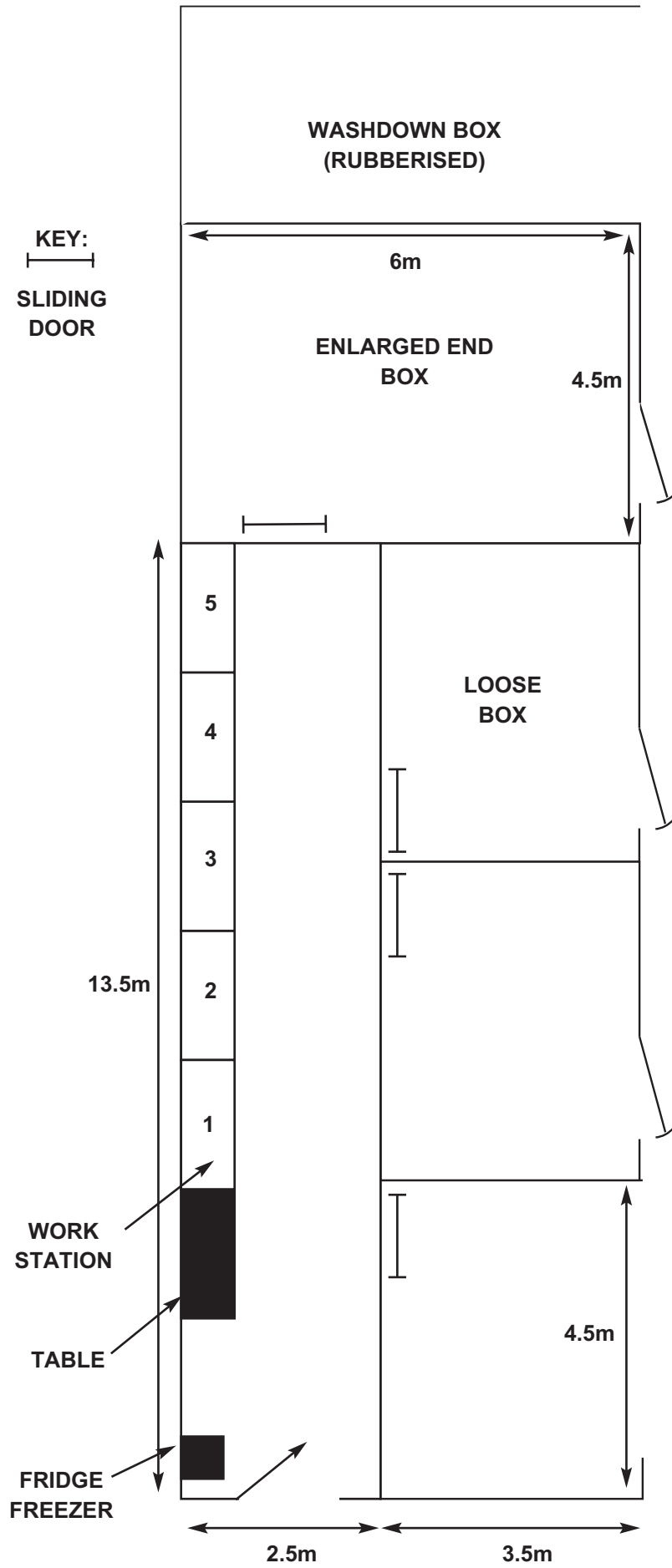

WORK STATIONS IN THE SAMPLING UNIT
FIG. 7.B

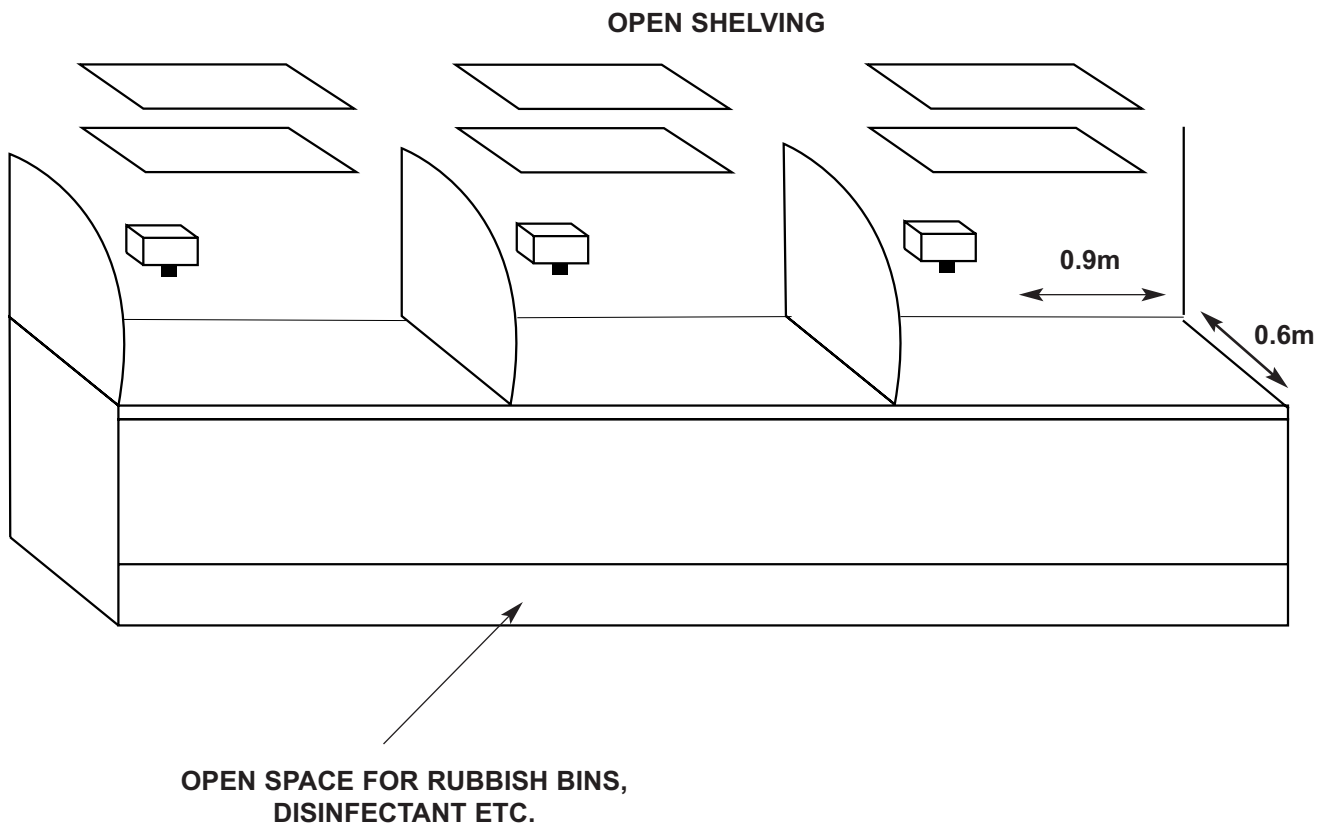



Photo 7.A Sampling Unit (Work Station) – Ascot

Section 8

JUDGE'S BOX,
PHOTOFINISH
INSTALLATION,
FINISHING LINE AND
COMMENTARY BOX

Section 8: JUDGE'S BOX, PHOTOFINISH INSTALLATION, FINISHING LINE AND COMMENTARY BOX

8.1 JUDGING AND PHOTOFINISH INSTALLATION

8.2 JUDGE'S BOX

Location
Sight lines
Dimensions
Layout
Windows
Canopy
Fittings
Electrical
Communications

8.3 PHOTOFINISH INSTALLATION

Dimensions
Specification
Location
Sight Lines
Camera Platform
Windows
Work Bench
Electrical
Communications
Public Address
Access

8.4 FINISHING LINE

Layout
The Winning Post
Moveable Winning Post
Gaps in the Running Rails
Camera Side Enclosure

8.5 COMMENTARY BOX

Location
Access
Construction
Furnishing
Electrical
Technical
General

Section 8: JUDGE'S BOX, PHOTOFINISH INSTALLATION, FINISHING LINE AND COMMENTARY BOX

8.1 JUDGING AND PHOTOFINISH INSTALLATION

The positions of the Photofinish Installation and of the finishing line are mutually related. The finishing line must be perpendicular to the line of run-in of horses approaching it, and the Photofinish Installation must be on a prolongation of this finishing line. A complex optical relationship must be satisfied, encompassing the height above the racing surface of the Photofinish Installation, its horizontal distance from the running rail, and the width and layout of the course at the finish, in order for Photofinish cover to meet BHA requirements.

It is essential that an integrity technical service provider and the British Horseracing Authority Racecourse Department are consulted before any decision is taken over the position of the Photofinish Installation or the layout of the course at the finish.

The Judge's Box must also be positioned on a prolongation of the finishing line, and should be below the Photofinish Installation. The racecourse commentary box is usually best located adjacent to the Judges Box, with the Broadcast Television Commentary Box situated next to the Photofinish Installation.

8.2 JUDGE'S BOX

Location

The Judge's Box may be provided within a stand or a free-standing tower. It should be located on the stands side of the course (unless the situation makes this impractical), in order to achieve ease of access and a good view of the entire course. It should be angled at 10-20 degrees to the track. The height of the box and its distance from the far winning post will be determined by the requirements of the Photofinish cameras positioned immediately above the Judge's Box. At ground base level, the distance between the Judge's Box/Photofinish Installation and the Photofinish mirror on the far side of the course will, ideally, not exceed 85m.

Sight Lines

The Judge's Box should give an unrestricted view of the whole course, and must provide a clear and unobstructed view from the last six furlongs or the finishing straight (whichever is further) to one furlong after the winning line, or the bend (whichever is further).

Dimensions

The box must be a minimum of 2.5m x 2.5m (see Fig. 8.B).

Layout

The box must be arranged so that the Judge is positioned on a prolongation of the finishing line. This line should be 1.4m from the side of the box from which the horses are approaching. A second person (a trainee Judge, for example) must also be able to be accommodated and to view racing. The sides of the Judge's Box should be solid, providing that the Judge has a clear view of the racecourse (see above: *Sight Lines*).

Windows

The front windows must be sliding panels with the thinnest possible frames (of which there may be three or at most five), which slide to the non-racing side. The edge of the panes, when in the open position, should not be less than 45cm away from the winning line. Side windows should be louvred. All panes must be constructed from glass.

Canopy

A canopy must be fitted to the front of the Judge's Box, which will overhang the viewing aperture by 60cm. The front edge of the canopy should be 20-30cm above the Judge's eye level when seated. A gutter must be provided. The underside of the canopy must be painted a dark colour to prevent glare and the canopy must not interfere with sight lines from other positions.

Fittings

There must be a bench 30cm deep with the front edge 84cm high from ground level, sloping 10 degrees below the horizontal along the front of the box. It should have a lip to prevent papers falling off, should be of a dark colour and have a matt surface. The bench should extend from 30cm on the racing side of the winning line to at least 60cm on the non-racing side.

One swivel chair (with adjustable height and backrests), as well as a further chair for guests, is required. A standard computer table, at least 60cm long (and preferably with adjustable height), will also be required to be positioned at right-angles to the angled work bench on the racing side of the Judge. There should be a floor covering of carpet. Coat hooks should be provided on the side or back wall. The door must be lockable with a sign reading: 'Judge – Private' and the walls and ceilings should be painted matt black or dark grey.

Electrical

There must be lighting to a minimum level of 100w (or 40w fluorescent). Heating must be provided – a fan heater under the bench or to one side is recommended. Four 13 amp switched sockets are required above the computer table, on the track facing wall, to the racing side of the winning line. An integrity service provider will specify all requirements for cables, terminations and electrical supplies for their technical equipment in the Judge's Box.

Communications

A telephone line must be provided linking the Judge's Box with the Broadcast Office. There must also be a loudspeaker (with volume control) connected to the PA system.

A means must also be in place to allow the official result (from the photo finish equipment) to be returned to Weatherbys electronically via the wireless network connection available in the photo finish installation. Racecourse Executives should contact the BHA Racecourse Department for details of the format, schema and structure that should be used to return the photo finish official results data.

An electronic feed of pre-photo finish data is available from Weatherbys. The format and method of this electronic feed can also be obtained from the BHA Racecourse Department.

See BHAGI 4.2.

8.3 PHOTOFINISH INSTALLATION

Dimensions

The Photofinish Installation must be a minimum of 2.75m wide x 2.5m deep.

Specification

The Photofinish Installation and finishing line must be installed in accordance with integrity service provider specifications, which should be obtained from the provider before any design is commenced. The provider will be able to advise further with regard to all details relating to Photofinish provision, and should therefore be consulted on its installation from the outset.

Location

The Photofinish Installation must be located so that the cameras may be positioned within it as follows:

- on the precise prolongation of the finishing line(s);
- at the correct height above the racing surface, producing an angle of depression from the mirror camera to the centre of the mirror of approximately 17 degrees;
- at a distance from the running rail as has been specified by the integrity service provider (see Fig. 8.A).

The Photofinish Installation should be on the stand side of the course (unless the situation makes this impractical) in order to achieve ease of access and a good view of the whole course.

Sight Lines

From the Photofinish Installation there must be an unobscured view of the whole of the racing surface from at least the last 2 furlongs, or the last fence or hurdle (whichever is the furthest away), up to at least 20m beyond the finishing line.

Camera Platform

A double-camera platform is required. In most cases, this will be supplied and surveyed in position by the integrity service provider. The position and alignment of the platform must be taken into account when deciding on the internal arrangement of the camera room. The platform has to hold two cameras weighing up to 10kg each, and must be of strong and rigid construction, with substantial areas for fixing, in order to prevent vibration.

Windows

An outward opening window on the winning line 1m high x 0.5m wide will be required for the cameras, with glazed panels on either side for the operator to view racing.

Work Bench

A single, permanently installed bench will be specified, which will be supplemented by a computer table supplied by the integrity service provider. The integrity service provider will also specify cable routing to and within the Photofinish Installation.

Electrical

A power supply of 10 KVA is required for technical services within the Photofinish Installation. An integrity service provider will specify the arrangement of circuits, outlets and protective devices; certain equipment will require individual protection measures. It is essential that safety regulations are strictly observed. The temperature of the room must be maintained between 10 and 28 degrees centigrade.

Communications

The termination of the network link from the Stewards Room should be a wall mounted RJ45 terminal. The wireless equipment for the electronic return of the official result will be installed by or on behalf of the British Horseracing Authority. This equipment requires a minimum of two 13 amp switch sockets.

See BHAGI 8.1 and BHAGI 4.2.

Public Address

There must be a loudspeaker (with volume control) connected to the PA system.

Access

The access to the Photofinish Installation must be suitable for operators carrying heavy and bulky equipment. An integrity service provider must approve a detailed design of the access route; vertical ladders are not acceptable.

8.4 FINISHING LINE

Layout

The layout of the course at the finish must be agreed with the integrity service provider, so that the Photofinish Installation may provide cover of the finish in accordance with British Horseracing Authority requirements. The finishing line itself, and the positioning of the winning post, will be surveyed by the integrity service provider in relation to the positioning of the Photofinish cameras.

Note: This manual describes the simple layout for a single finishing line. Should the integrity service provider require a more complex layout, this will be specified for the racecourse concerned.

The Winning Post

The Winning Post marks the finish and is used to support the Photofinish mirror. It must be strong and rigid enough to be free from vibration caused by wind or other disturbances. The post should be made of 15cm x 7.5cm steel channel or timber. It should be set in concrete foundations, braced to steady the top, and painted matt vinyl emulsion pale duck egg blue, except for the top 30cm, which should be painted white. The mirror must cover the full width of the course for the mirror camera. Should the angle at which it is installed relative to the vertical axis of the post be too great to be accommodated by the standard camera brackets carried by integrity service providers, special brackets will need to be provided.

For the security and siting of the winning post, see BHAGI 3.4.

Moveable Winning Post

A moveable winning post may be required for use when dolling off on the winning post side of the course at the finishing line. An integrity service provider can supply suitable equipment for purchase if required.

See BHAGI 3.4.

Gaps in the Running Rails

A gap is required in the Running Rail on the camera side, so that the view by the cameras of the horses is not obscured by the Running Rail. The end of the rail beyond the finish line must be rounded, in order to prevent injury should a horse or rider clip it.

Camera Side Enclosure

An enclosure may be needed on the camera side of the course in order to prevent spectators from obscuring the camera's view of the finishing line. This enclosure should extend 1.2m to each side of the finishing line. If required, this will be detailed as part of the finishing line survey.

8.5 COMMENTARY BOX

Note: The Commentary Box is not under the remit of BHA as the Racecourse Licensing Authority.

Location

The Commentary Box must be sited on the same side of the racecourse as the side-on camera(s), with an unobstructed view of the entire race track (see Fig. 8.C). The arc of vision shall not be obstructed by other racing personnel (e.g. Stewards, cameramen etc.).

The Commentary Box must be in line with the winning post, or not more than 30 degrees before the winning post or 10 degrees after it, these angles being measured from the running rail (Fig. 8.C). On courses where the grandstands are very close to the race track, these angles may be increased to 45 degrees and 25 degrees respectively. The Box must be sited at the highest point within or on top of the grandstand as practicable, preferably at the same height (or higher) than the side-on camera. There must be an unobstructed view of the nearside running rail.

Access

Access must be through internal corridor and staircase, or external staircase/catwalk with safety handrail. Any external access shall have a non-slip surface and the use of vertical ladders is specifically prohibited. There shall be an alternative means of escape in the event of fire, conforming with local fire regulations.

Construction

The front of the box must open on to the racecourse, with a vertical aperture of 66cm and a horizontal aperture allowing for a full arc of vision (see above: *Location*) from a point situated 30cm rearwards of the front edge of the box and 1.5m from the approaching-end wall (Figs. 8.D/.E). The aperture may include part of the side wall of the box.

When not in use, the box aperture must be weatherproofed with either roller shutters, removable or lifting glass windows. Where the aperture includes part of the side wall, this section must be a sliding glass window, provided that the window slides back completely out of the arc of vision. If the box is exposed to rain when in use, some protection must be provided against ingress. This may be achieved by an extended roof line, or by a rigid canopy above the aperture.

Soft safety mesh must be provided below the entire opening of the aperture, in order to prevent any falling objects from causing injury, and the interior of the Commentary Box should be painted in a dark colour (preferably black).

Furnishing

A firmly fixed shelf, of softwood construction and capable of supporting a 10kg weight, must be provided at a height of 128cm above floor level (to the dimensions shown in Fig. 8.E). The main access door must close securely, and reasonable care should be taken to prevent ingress by birds or vermin when it is not in use. A chair (and separate table if space permits) should be provided, as should coat hooks. The box must be regularly cleaned.

Electrical

Two 13 amp switched sockets must be available, on the same electrical phase as the Weighing Room circuits, and a ceiling light of not less than 60W must be provided, with a switch near to the door. Consideration should also be given to the lighting of the access route to the Commentary Box.

Technical

The Box must be fitted with a PA loudspeaker (with volume control) and a CCTV outlet, as well as audio and video lines to the Broadcast Office and TV contractor. These must terminate below the shelf, where the video monitor is situated. A direct telephone line to the Broadcast Office must be provided.

General

The Commentator's Box must be for the sole use of the racecourse commentator and no other persons. Where a series of Commentary Boxes make up a single facility, adequate partitioning must be provided, in order to prevent noise pollution or distraction by other users during use.

Fig. 8.A

Fig. 8.B

Fig. 8.C

Fig. 8.D

Fig. 8.E

PHOTOFINISH POSITION
FIG. 8.A

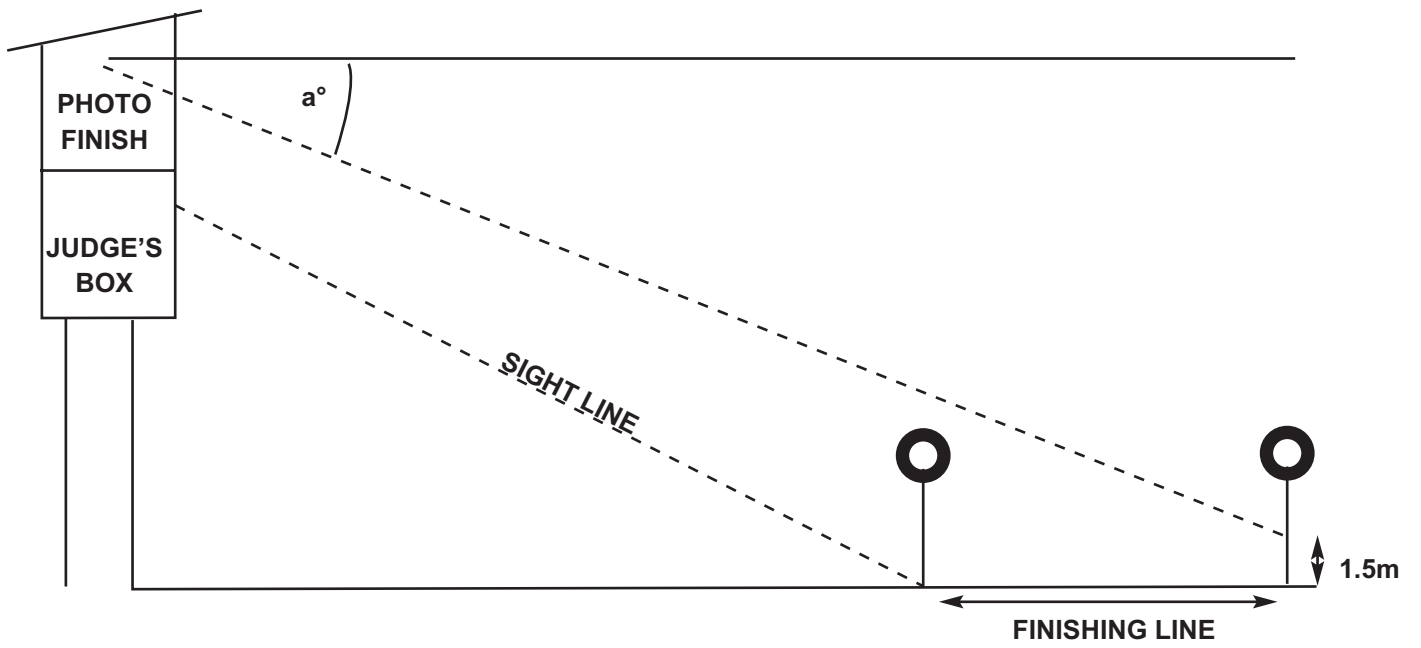

a° = ANGLE OF DEPRESSION
(17°)

COMMENTARY BOX LOCATION
FIG. 8.C

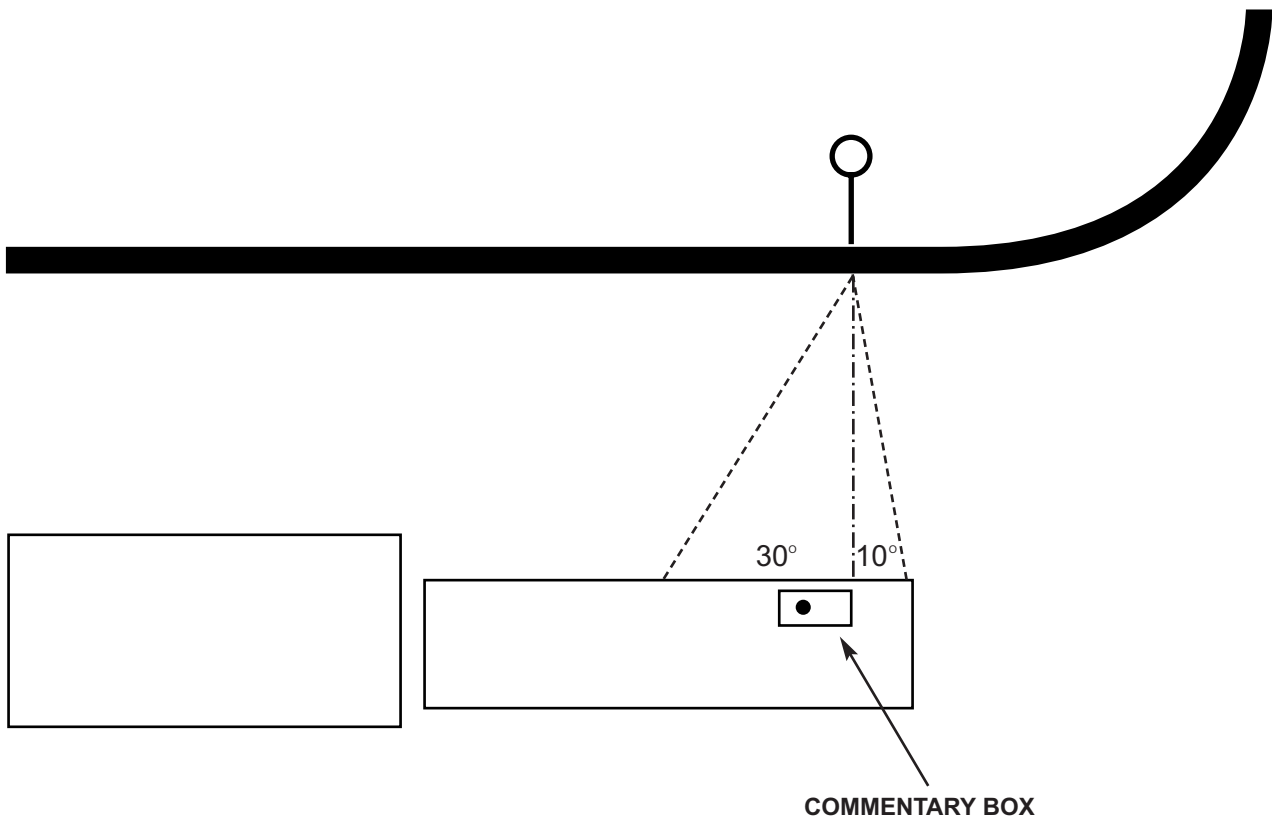
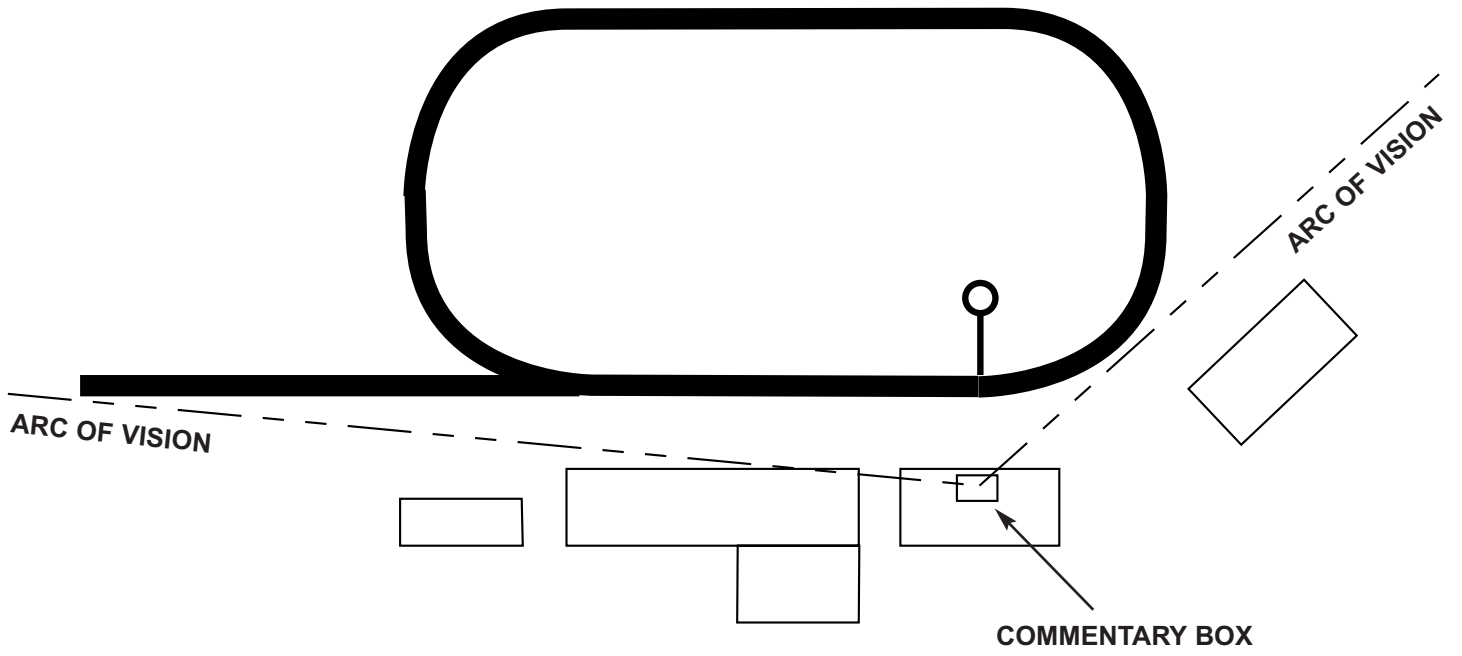

COMMENTARY BOX PLAN
FIG. 8.D

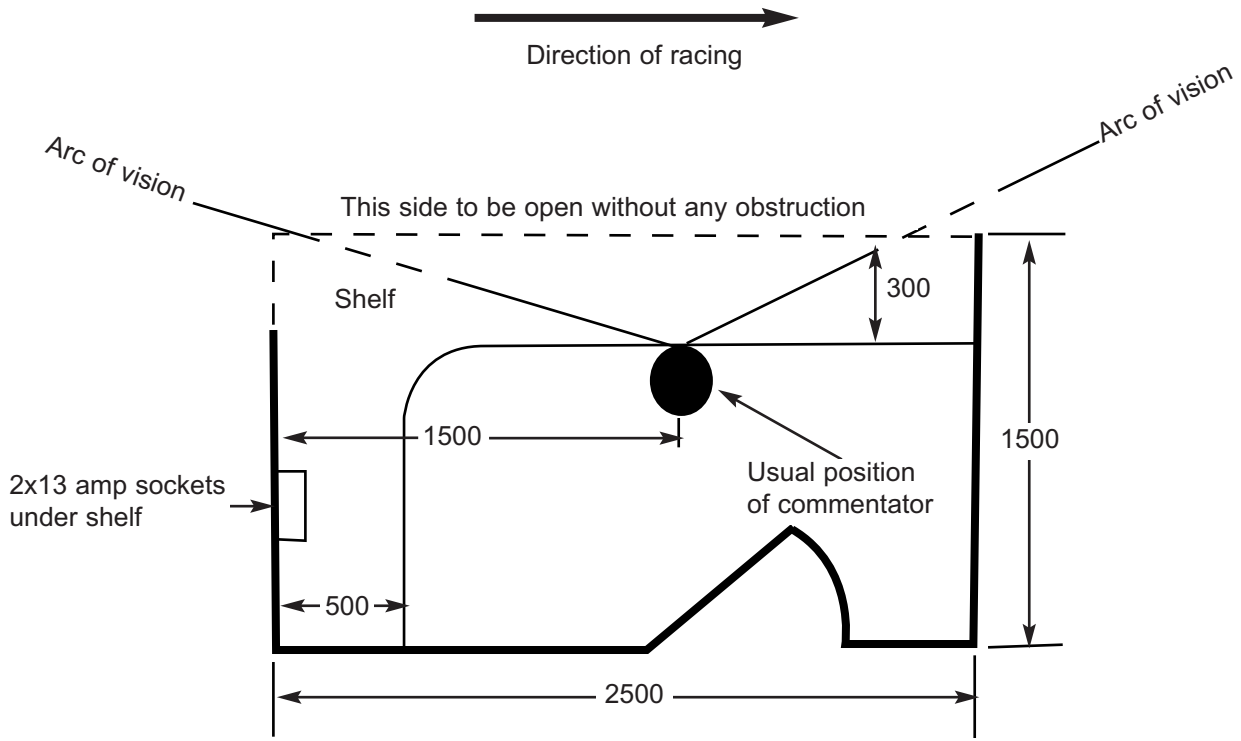

Dimensions in mm.
NOT TO SCALE

COMMENTARY BOX - ELEVATION
FIG. 8.E

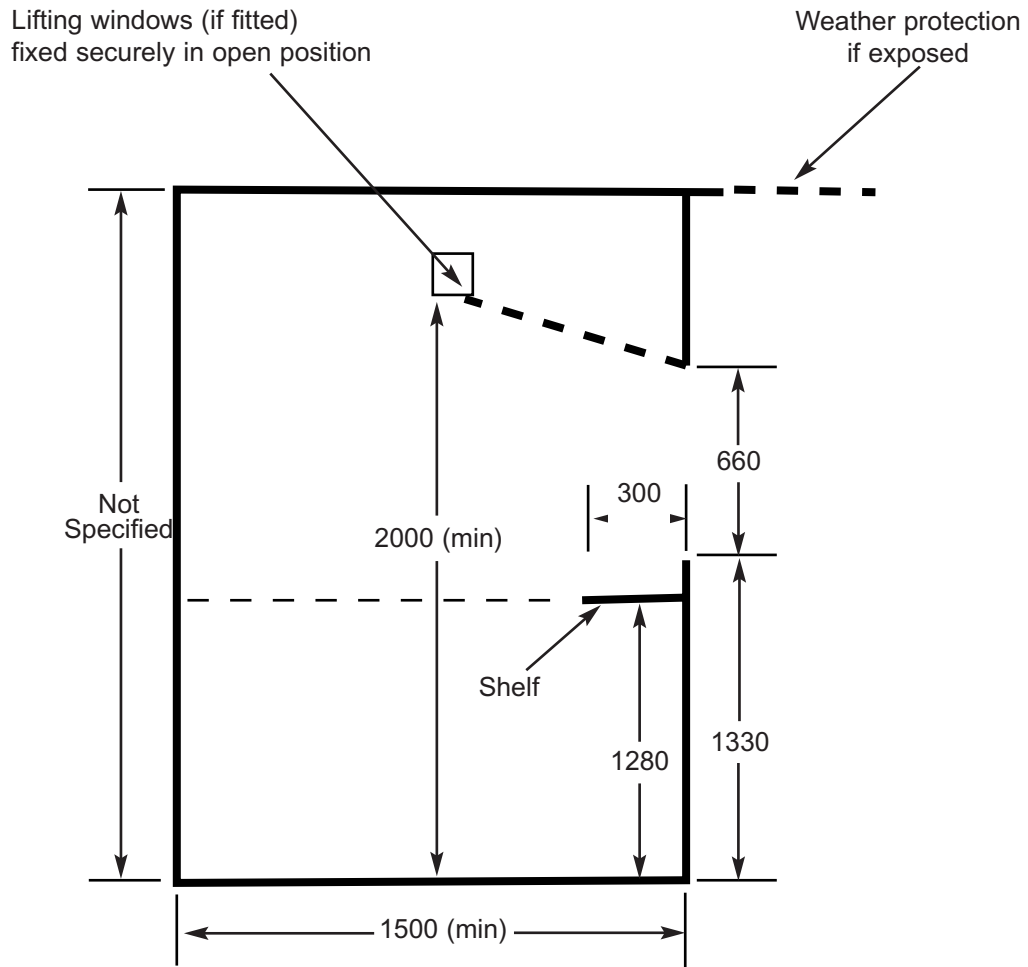

Dimensions in mm.
NOT TO SCALE

Section 9

TELEVISION **FACILITIES**

Section 9: TELEVISION FACILITIES

- 9.1 TELEVISION CAMERA PATROL SERVICE
- 9.2 CABLING
- 9.3 MOBILE CONTROL ROOM (MCR) POSITION
- 9.4 HEAD-ON CAMERA POSITION
- 9.5 SIDE-ON CAMERA POSITION
- 9.6 HOIST CAMERA POSITIONS

Section 9: TELEVISION FACILITIES

9.1 TELEVISION CAMERA PATROL SERVICE

The integrity service provider operates a number of television cameras, positioned to provide adequate surveillance of the whole racecourse for integrity purposes, at pre-selected and inter-related positions around the racecourse. The integrity service provider selects these positions in conjunction with the Clerk of the Course and a representative of the BHA Stipendiary Stewards Department to meet BHA (and other) requirements. These cameras are controlled (and their pictures recorded) at the integrity service provider's Mobile Control Room (MCR) vehicle, where live and recorded coverage of the racing is provided for the Stewards and programmes are produced for racecourse CCTV installations.

9.2 CABLING

The MCR is connected to head-on and side-on cameras, as well as to some remote cameras by TRI-AX camera cables. Through these cables, the signals controlling the camera, the picture from the camera, the electrical power to the camera and the talk back with the operator are passed. Care should be taken when planning positions, in order to minimise the length of cable runs required. The MCR is also linked to the Stewards' Enquiry Room, Stewards' Viewing Boxes, Judge's Box, Commentary Box, Broadcast Office and head end of the CCTV installation via a series of minor cables. Duct routes for cables are required between the MCR and the appropriate buildings. The integrity service provider must be consulted with regard to the number and size of ducts to be installed. Where cables terminate, the integrity service provider will supply suitable termination boxes, and will arrange for the installation and termination of all such cables.

9.3 MOBILE CONTROL ROOM (MCR) POSITION

A secure parking area, away from public thoroughfares and horsewalks, must be provided for the MCR vehicle, as well as for a satellite up-link vehicle, where required. The integrity service provider will also require parking places for a crew bus and hoist camera vehicles (when not deployed at positions around the racecourse). The hoist camera vehicles require an electrical supply from which to recharge batteries. Suitable access from public roads to the MCR position must be provided for a vehicle weighing up to 16 tonnes and 10-12m long x 3m wide. Location and design of the area used to accommodate these vehicles must allow for access steps and cable connections at the rear, and should be discussed and agreed in advance with the integrity service provider.

A main single phase electrical power supply of 125 amp single phase/63 amp three phase and neutral is required adjacent to the MCR position. The integrity service provider will supply an electrical power termination box, fitted with the necessary switching units. Positioning of this power supply must be agreed in advance with the integrity service provider. In the event of a mains

power failure, there must also be provision to enable at least the Head-on and Side-on Cameras to function.

9.4 HEAD-ON CAMERA POSITION

The head-on camera (or cameras where a requirement for two exists) is usually mounted on a hoist vehicle, although a static tower may be used as an alternative. The camera must be accurately head-on to the line on which horses run when coming to the finishing line, and should have the ability to cover the whole of the racecourse. It is important to consult the integrity service provider as to the precise positioning of the vehicle or tower, as well as with regards to its construction. More than one such position will be needed when the run-in varies according to the part of the course on which horses are running. Each position for a vehicle must have a hard standing, area. It must also be possible for the vehicle to move freely between separate positions.

9.5 SIDE-ON CAMERA POSITION

This permanent position must be situated high on a stand (or other structure), and positioned both close to and before the finishing line. It must also be set back a sufficient distance from the course, with an unobscured view of the whole course wherever possible.

The integrity service provider must be consulted on the location and design of this position. Access to this position must be suitable for the carriage of heavy equipment.

9.6 HOIST CAMERA POSITIONS

Hoist Camera positions must be provided for either a hoist or a camera tower, as agreed between the Racecourse Executive, BHA and the integrity service provider. These must be sited by the integrity service provider, in order to ensure that the cameras can be positioned correctly. For a hoist vehicle, there must be vehicular access and a hard standing area. Where a camera tower is provided, it will be sufficient for a vehicle to be able to unload the equipment required near to the tower.

See BHAGI 4.1.

Section 10

STEWARDS' VIEWING BOXES

Section 10: STEWARDS' VIEWING BOXES

10.1 LOCATION

10.2 MAIN VIEWING BOX
Size, layout and access
Sight lines and position
Communications

10.3 SECONDARY VIEWING BOX
Installation
Size, layout and access
Sight lines and position

Section 10: STEWARDS' VIEWING BOXES

10.1 LOCATION

Both the Main and Secondary Boxes should be of sufficient height to command an overall view of the racecourse. The Acting Stewards and Stipendiary Stewards must be able to view the entire race, from its start to the finish.

10.2 MAIN VIEWING BOX

Size, layout and access

The Main Viewing Box (see Photo 10.A) is side-on to the racecourse. The box must have a minimum front width of 6m and a depth of 4m to accommodate a minimum of six people (2 Stewards, Stipendiary Steward, Handicapper, Clerk of the Course and Veterinary Officer). There must be swivel type seating for 4 people, with shelf rests for paperwork/documentation. Coat hooks should be provided.

There must also be sufficient space to provide an uninterrupted view of an instant race replay on the integrity service providers' 21" video monitor to all seated occupants. Where a show of betting information is provided, there should be a separate TV or monitor screen available to display this. Monitor and TV screens should be positioned so that they cannot be affected by rain or glare. A PA system (with volume control) is also required.

Access from the Main Viewing Box to the Stewards' Room after a race must be such that it takes no longer to go from one to the other than it takes the jockeys to return from the course and weigh in. When positioned in the main body of a large modern stand, private lifts for the Stewards may have to be considered in order to achieve this.

Sight lines and position

The Main Viewing Box must be positioned so that those watching racing from within it have an uninterrupted view of an entire race from its start to the finish. It is not possible to read a race properly if there are gaps in the field of vision. This is best achieved by sliding windows, or windows that open outwards and upwards. There must be no obstructions caused by pillars, window brackets/frames or racecourse buildings in the centre of the course. The existing location of the Main Viewing Box must always be taken into account when new buildings are planned, as they may affect existing sight lines.

The Main Viewing Box should be as high as reasonable access will allow, and will usually be situated just short of the finishing line, unless the Judge is on a higher level to it, when it should be situated on the finishing line itself.

Communications

Both external and internal telephone facilities are required. A three-way telephone system must be available for the Stewards to communicate with each other directly from their various positions immediately after a race.

10.3 SECONDARY VIEWING BOX

Installation

The BHA must be consulted prior to the installation of any Secondary Viewing Box. On occasion, such boxes may not be required.

Size, layout and access

The Secondary Viewing Box must be situated high enough to obtain the same overall view as though it were the Main Box, as well as big enough to accommodate two people (seated), with shelf rests provided. The interior dimensions of the box must be a minimum of 2m x 2m. Coat hooks should be provided (see Fig. 10.A).

The Box should feature a substantial roof overhang, with an elongated and down-turned lip. A 21" video monitor will be provided by the integrity service provider, as well as PA loudspeaker (with volume control). All-round vision in wet weather is achieved by the use of sliding windows fitted at the sides of the box, or by having windows that open upwards and outwards (see Section 10.2). At those racecourses racing during the winter, a heating system must be installed.

Access will normally be via a stairway, which should have an angle of pitch of not more than 42 degrees, have no more than 16 risers in any one flight, and have hand rails on either side. Treads should be non-slip. The door at the rear of the box must open onto an appropriately-sized and railed landing.

Sight lines and position

Where topographic constraints permit, the Secondary Viewing Box should have an uninterrupted view of the whole course. It must, however, be situated high enough to be able to see over the leading horses in the finishing straight (when Flat racing), and the ground on the landing side of the second last fence or hurdle (when Jump racing). This should be achieved with a floor level height of 7.5m.

The Box must be set back at least 45m from the winning line and be in a true head-on position. It must have a telephone link to both the Main Stewards' Viewing Box and the Stewards' Room in the Weighing Room Complex.

See BHAGI 8.1.

Fig. 10.A

Photo 10.A Stewards' Box – Ascot

SECONDARY VIEWING BOX FIG. 10.A

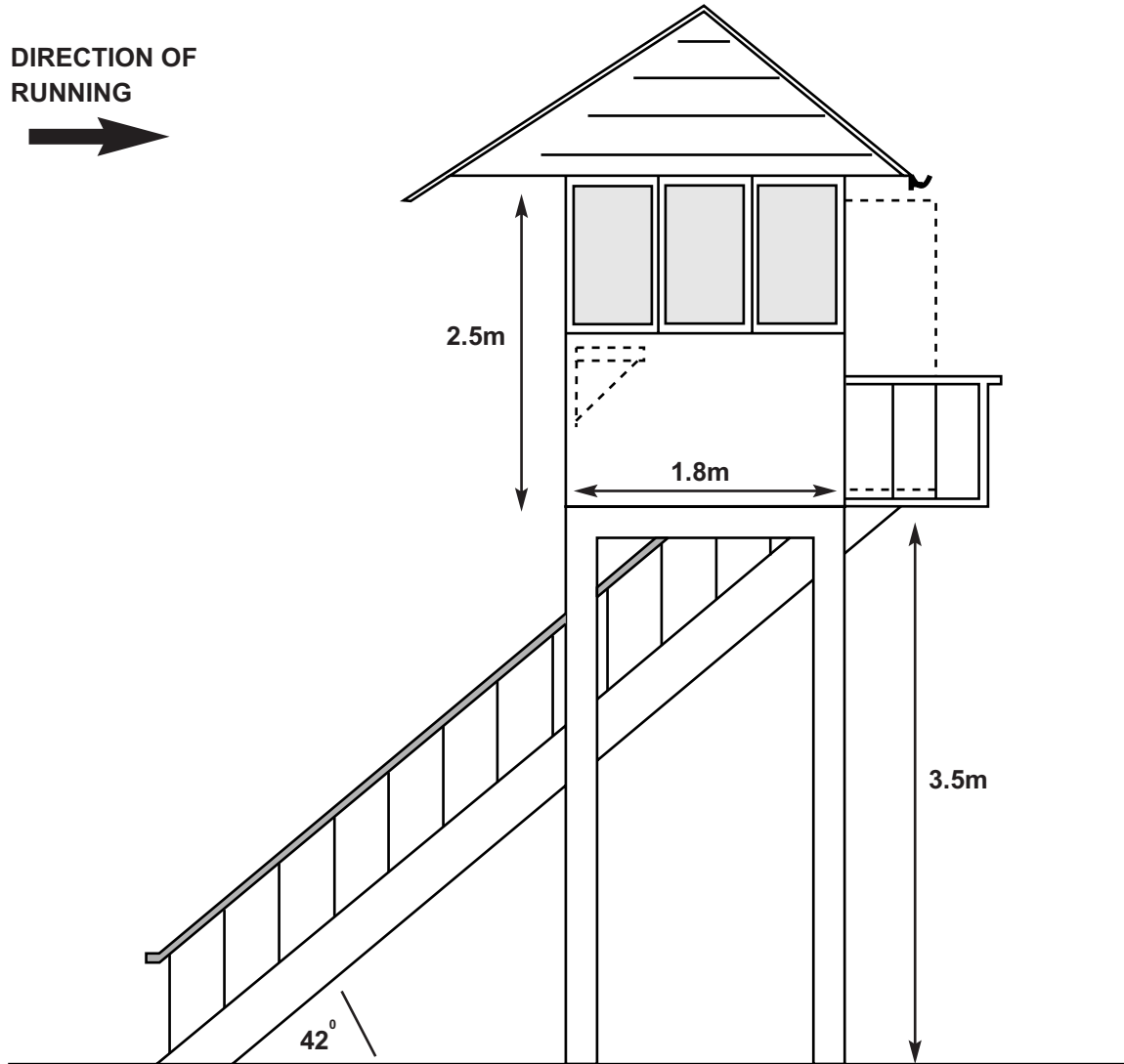



Photo 10.A Stewards' Viewing Box – Ascot

INDEX

Banking of Bends	1.5
Boom Irrigation (photo)	Photo 1.A
Broadcast Office	5.5
Cabling	9.2
Canteen and Overnight Accommodation Facilities	3.10
Canter Downs	1.14
Clerk of the Course's Room	5.7
Commentary Box – Elevation (illustration)	Fig. 8.E
Commentary Box Location (illustration)	Fig. 8.C
Commentary Box Plan (illustration)	Fig. 8.D
COURSE, THE	Section 1
Crossings	1.9
Declarations Room/Counter/Desk	5.4
Distances from Finish to Bends	1.7
Distances from Starts to Bends	1.6
Drainage	1.11
Emergency Service Road	1.13
Finishing Line	8.4
Floodlighting	1.15
Floodlighting (photo)	Photo 1.B
General Media Facilities	5.15
Handicapper's Room	5.6
Head-on Camera Position	9.4
Hoist Camera Positions	9.6
Horse Box Park	3.4
Horsewalks	4.4
Hurdle (photo)	Photo 1.E
Jockeys' Changing Room	5.9
Jockeys' Changing Room (photo)	Photo 5.B
JOCKEYS' MEDICAL ROOM	Section 6
Jockeys' Medical Room Dimensions	6.2
Jockey's Medical Room Fittings	6.4
Jockeys' Medical Room (illustration)	Fig. 6.A
Jockeys' Medical Room Layout	6.3
Jockeys' Medical Room Location	6.1
Jockeys' Medical Room (photos)	Photos 6.A/.B
Jockeys' Rest Room	5.11
Jockeys' Rest Room (photo)	Photo 5.D
JUDGE'S BOX, PHOTOFINISH INSTALLATION, FINISHING LINE AND COMMENTARY BOX	Section 8
Judge's Box Plan (illustration)	Fig. 8.B

Lay-by (illustration)	Fig. 1.B
Loading/Unloading Ramp (illustration)	Fig. 3.C
Location of (Stewards') Viewing Boxes	10.1
Loose Box (photo)	Photo 3.B
Main (Stewards') Viewing Box	10.2
Mobile Control Room Position	9.3
Obstacles	1.16
OFFICIAL STABLES COMPLEX	Section 3
Official Stables Complex (illustrations)	Figs. 3.A/.B
Official Stables Complex Layout	3.3
Official Stables Complex Location	3.2
Official Stables Complex (photo)	Photo 3.A
Open Ditch (photo)	Photo 1.D
Paddock, Diagrammatic Layout (illustration)	Fig. 4.A
PADDOCK, THE	Section 4
Parade Ring	4.3
Perimeter Barrier (Official Stables Complex)	3.5
Photofinish Installation	8.3
Photofinish Position (illustration)	Fig. 8.A
Plain Fence (photo)	Photo 1.C
Pre-Parade Ring	4.2
Press Interview Room	5.14
Press Room (photo)	Photo 5.E
Public Address Installation	5.12
Race Distances	1.2, 1.3
Race Timing	2.5
Racecourse Layout (illustration)	Fig. 1.A
Racing Surfaces	1.8
Running Rail	1.12
Saddling Boxes	4.1
Saddling Boxes (photo)	Photo 4.A
Sampling Unit	7.1
Sampling Unit (photo)	Photo 7.A
Sampling Unit Work Stations (illustrations)	Figs. 7.A/.B
Scales	5.3
Scales Area in Weighing Room (photo)	Photo 5.A
Secondary (Stewards') Viewing Box	10.3
Secondary (Stewards') Viewing Box (illustration)	Fig. 10.A
Security Accommodation	3.6
Side-on Camera Position	9.5
Specification for Loose Boxes	3.7
Starters' Rostrum	2.2
Starter's Rostrum (illustration)	Fig. 2.A
Starting Gates	2.4
Starting Stalls	2.3

STARTS	Section 2
Stewards' Room	5.8
STEWARDS' VIEWING BOXES	Section 10
Stewards' Viewing Box (photo)	Photo 10.A
Television Camera Patrol Service	9.1
TELEVISION FACILITIES	Section 9
Unsaddling Enclosure	4.5
Valets' Room	5.10
Valets' Room (photo)	Photo 5.C
VETERINARY FACILITIES	Section 7
Veterinary Facilities - Other Requirements	7.3
Veterinary Treatment Box	7.2
Watering Systems	1.10
WEIGHING ROOM COMPLEX	Section 5
Weighing Room Complex (illustration)	Fig. 5.A
Weighing Room Complex Layout	5.1
Width of Track	1.2, 1.3

RACECOURSE MANUAL

THE BRITISH HORSERACING AUTHORITY

